



FOOD PREP TABLES

BACK BONE OF FOOD SERVICE WITH ALMOST LIMITLESS OPTIONS

SANDWICH PREP

Full electronic control

Heavy-duty aluminum pan liner

easy to clean and prevents spills from falling into cabinet while also ensuring coldest air flows across bottom of pans

Reversible cutting boards

1/2" thick, 10" deep

Locking divider bars

Field reversible doors

with 120 degree stay-open feature

Two epoxy coated shelves

per door section standard

Snap-in door gaskets

Accommodates up to 6" deep food service pans

4" deep 1/6 size polycarbonate pans are included

Heavy duty insulated covers

protects products and eliminates sweating when closed

6" heavy duty casters standard

3" casters or 6" leg option available at no charge when specified on order



DESIGNED TO PERFORM IN HIGH AMBIENT CONDITIONS

3 YEAR PARTS & LABOR WARRANTY WITH AN ADDITIONAL 4 YEAR COMPRESSOR WARRANTY

MADE IN USA



PERFECT SEAL PAN LINER
ensures airflow under pans and protects bottom of cabinet from pan spills



CLEAR LIDS AVAILABLE
for optimized product display

ACCESS OPTIONS

- Doors
- Drawers
- Dual-sided

AGENCY CERTIFICATIONS



Food Prep Tables



EXTERIOR FINISHES

- Stainless steel with galvanized back
- Stainless steel with stainless back

INTERIOR FINISHES

- Corrosion-resistant aluminum
- Stainless steel

AVAILABLE ACCESSORIES

- 12" crossbar
- Side/front crumb catchers
- Overshelf kits
- Composite cutting boards
- Bun tray rack
- Locks (for solid doors)

AVAILABLE OPTIONS

- Left hand hinge doors
- Remote models available

LID OPTIONS

- Clear lids
- Flat-hinged lids
- Lift-off lids
- See-thru lids

MOUNTING OPTIONS

- 6" casters
- 3" casters (allows for ADA compliant working height)
- 6" legs

SANDWICH PREP

Standard Top

DOORS

MAINTAINS PRODUCT TEMPERATURES OF 36-38°F.

MODEL WIDTH	MODEL #	DOORS/ SHELVES	VOLTS	HP	AMPS	CUBIC FEET	WIDTH	DEPTH	HEIGHT	CRATED WEIGHT	STANDARD PANS 4" DEEP
27" 1 DOOR	SPE27HC	1/2	115	1/6	2	6.91	27	32	39.25	202	(6) 1/6 size, (2) 1/9 size
	SPE27HC-B										(8) 1/6
32" 1 DOOR	SPE32HC-08	1/2	115	1/6	2	8.01	32	32	39.25	239	(8) 1/6 size
36" 2 DOORS	SPE36HC-08	2/4	115	1/6	2	10.01	36	32	39.25	250	(8) 1/6 size
	SPE36HC-10									252	(10) 1/6 size
48" 2 DOORS	SPE48HC-08	2/4	115	1/6	2.2	13.01	48	32	39.25	296	(8) 1/6 size
	SPE48HC-10									296	(10) 1/6 size
	SPE48HC-12									302	(12) 1/6 size
60" 2 DOORS	SPE60HC-08	2/4	115	1/3	5.4	16.02	60	32	39.25	346	(8) 1/6 size
	SPE60HC-10									348	(10) 1/6 size
	SPE60HC-12									342	(12) 1/6 size
	SPE60HC-16									360	(16) 1/6 size
72" 3 DOORS	SPE72HC-08	3/6	115	1/3	5.4	20.02	72	32	39.25	432	(8) 1/6 size
	SPE72HC-10									432	(10) 1/6 size
	SPE72HC-12									398	(12) 1/6 size
	SPE72HC-18									388	(18) 1/6 size

For total height, add 3 or 6 inches, based on your mounting choice. Depth measurement includes handles.

CONDIMENT STATIONS WITH SNEEZEGUARD

MAINTAINS PRODUCT TEMPERATURES OF 36-38°F.

MODEL WIDTH	MODEL #	DOORS/ SHELVES	VOLTS	HP	AMPS	CUBIC FEET	WIDTH	DEPTH	HEIGHT	CRATED WEIGHT	STANDARD PANS 4" DEEP
27"	SPE27HC-SNZ	1/2	115	1/6	2	7.3	27	32	53	202	(6) 1/6 pans, (2) 1/9
48"	SPE48HC-12-SNZ	2/4	115	1/6	2.2	13.9	48	32	53.13	308	(12) 1/6 pans

AVAILABLE OPTIONS

SUFFIX	OPTION
24	Left hand hinge doors
R	Remote models available
Append suffix to model # when placing order	

DRAWERS

MAINTAINS PRODUCT TEMPERATURES OF 36-38°F.

MODEL WIDTH	MODEL #	DRAWERS	DOORS/SHELVES	VOLTS	HP	AMPS	CUBIC FEET	WIDTH	DEPTH	HEIGHT	CRATED WEIGHT	STANDARD PANS 4" DEEP
27"	SPED27HC	2	–	115	1/6	2	6.91	27	32	39.25	232	(6) 1/6 size & (2) 1/9 size
	SPED27HC-B	2	–								238	(8) 1/6 size
32"	SPED32HC-08-2	2	–	115	1/6	2	8.01	32	32	39.25	269	(8) 1/6 size
36"	SPED36HC-08-2	2	–	115	1/6	2	10.01	36	32	39.25	276	(8) 1/6 size
	SPED36HC-10-2	2	–								278	(10) 1/6 size
48"	SPED48HC-08-2	2	1/2	115	1/6	2.2	13.01	48	32	39.25	358	(8) 1/6 size
	SPED48HC-08-4	4	–								358	(8) 1/6 size
	SPED48HC-10-2	2	1/2	115	1/6	2.2	13.01	48	32	39.25	326	(10) 1/6 size
	SPED48HC-10-4	4	–								326	(10) 1/6 size
	SPED48HC-12-2	2	1/2	115	1/6	2.2	13.01	48	32	39.25	332	(12) 1/6 size
	SPED48HC-12-4	4	–								356	(12) 1/6 size
60"	SPED60HC-08-2	2	1/2	115	1/3	5.4	16.02	60	32	39.25	404	(8) 1/6 size
	SPED60HC-08-4	4	–								404	(8) 1/6 size
	SPED60HC-10-2	2	1/2	115	1/3	5.4	16.02	60	32	39.25	356	(10) 1/6 size
	SPED60HC-10-4	4	–								406	(10) 1/6 size
	SPED60HC-12-2	2	1/2	115	1/3	5.4	16.02	60	32	39.25	408	(12) 1/6 size
	SPED60HC-12-4	4	–								402	(12) 1/6 size
	SPED60HC-16-2	2	1/2	115	1/3	5.4	16.02	60	32	39.25	382	(16) 1/6 size
	SPED60HC-16-4	4	–								414	(16) 1/6 size
72"	SPED72HC-08-2	2	2/4	115	1/3	5.4	20.02	72	32	39.25	450	(8) 1/6 size
	SPED72HC-08-4	4	1/2								450	(8) 1/6 size
	SPED72HC-08-6	6	–								456	(8) 1/6 size
	SPED72HC-10-2	2	2/4	115	1/3	5.4	20.02	72	32	39.25	448	(10) 1/6 size
	SPED72HC-10-4	4	1/2								450	(10) 1/6 size
	SPED72HC-10-6	6	–								452	(10) 1/6 size
	SPED72HC-12-2	2	2/4	115	1/3	5.4	20.02	72	32	39.25	418	(12) 1/6 size
	SPED72HC-12-4	4	1/2								442	(12) 1/6 size
	SPED72HC-12-6	6	–								484	(12) 1/6 size
	SPED72HC-18-2	2	2/4	115	1/3	5.4	20.02	72	32	39.25	432	(18) 1/6 size
	SPED72HC-18-4	4	1/2								460	(18) 1/6 size
	SPED72HC-18-6	6	–								484	(18) 1/6 size

For total height, add 3 or 6 inches, based on your mounting choice. Depth measurement includes handles.

SANDWICH PREP

Clear Lid Standard Top

DOORS

MAINTAINS PRODUCT TEMPERATURES OF 36-38°F.

MODEL WIDTH	MODEL #	DOORS/SHELVES	VOLTS	HP	AMPS	CUBIC FEET	WIDTH	DEPTH	HEIGHT	CRATED WEIGHT	STANDARD PANS 4" DEEP
27" 1 DOOR	SPE27HC-CL	1/2	115	1/6	2	6.91	27	32	44.75	202	(6) 1/6 size, (2) 1/9 size
	SPE27HC-B-CL										(8) 1/6
32" 1 DOOR	SPE32HC-08-CL	1/2	115	1/6	2	8.01	32	32	44.75	239	(8) 1/6 size
36" 2 DOORS	SPE36HC-08-CL	2/4	115	1/6	2	10.01	36	32	44.5	250	(8) 1/6 size
	SPE36HC-10-CL									252	(10) 1/6 size
48" 2 DOORS	SPE48HC-08-CL	2/4	115	1/6	2.2	13.01	48	32	44.5	296	(8) 1/6 size
	SPE48HC-10-CL									296	(10) 1/6 size
	SPE48HC-12-CL									302	(12) 1/6 size
60" 2 DOORS	SPE60HC-08-CL	2/4	115	1/3	5.4	16.02	60	32	44.5	346	(8) 1/6 size
	SPE60HC-10-CL									348	(10) 1/6 size
	SPE60HC-12-CL									342	(12) 1/6 size
	SPE60HC-16-CL									360	(16) 1/6 size
72" 3 DOORS	SPE72HC-08-CL	3/6	115	1/3	5.4	20.02	72	32	44.5	432	(8) 1/6 size
	SPE72HC-10-CL									432	(10) 1/6 size
	SPE72HC-12-CL									398	(12) 1/6 size
	SPE72HC-18-CL									388	(18) 1/6 size

NEW

AVAILABLE OPTIONS	
SUFFIX	OPTION
24	Left hand hinge doors
R	Remote models available
Append suffix to model # when placing order	

For total height, add 3 or 6 inches, based on your mounting choice. Depth measurement includes handles.

CLEAR LIDS



DRAWERS

MAINTAINS PRODUCT TEMPERATURES OF 36-38°F.

MODEL WIDTH	MODEL #	DRAWERS	DOORS/SHELVES	VOLTS	HP	AMPS	CUBIC FEET	WIDTH	DEPTH	HEIGHT	CRATED WEIGHT	STANDARD PANS 4" DEEP
27"	SPED27HC-CL	2	–	115	1/6	2	6.91	27	32	44.75	232	(6) 1/6 size & (2) 1/9 size
	SPED27HC-B-CL	2	–								238	(8) 1/6 size
32"	SPED32HC-08-2-CL	2	–	115	1/6	2	8.01	32	32	44.75	269	(8) 1/6 size
36"	SPED36HC-08-2-CL	2	–	115	1/6	2	10.01	36	32	44.5	276	(8) 1/6 size
	SPED36HC-10-2-CL	2	–								278	(10) 1/6 size
48"	SPED48HC-08-2-CL	2	1/2	115	1/6	2.2	13.01	48	32	44.5	358	(8) 1/6 size
	SPED48HC-08-4-CL	4	–								358	(8) 1/6 size
	SPED48HC-10-2-CL	2	1/2	115	1/6	2.2	13.01	48	32	44.5	326	(10) 1/6 size
	SPED48HC-10-4-CL	4	–								326	(10) 1/6 size
	SPED48HC-12-2-CL	2	1/2	115	1/6	2.2	13.01	48	32	44.5	332	(12) 1/6 size
	SPED48HC-12-4-CL	4	–								356	(12) 1/6 size
60"	SPED60HC-08-2-CL	2	1/2	115	1/3	5.4	16.02	60	32	44.5	404	(8) 1/6 size
	SPED60HC-08-4-CL	4	–								404	(8) 1/6 size
	SPED60HC-10-2-CL	2	1/2	115	1/3	5.4	16.02	60	32	44.5	356	(10) 1/6 size
	SPED60HC-10-4-CL	4	–								406	(10) 1/6 size
	SPED60HC-12-2-CL	2	1/2	115	1/3	5.4	16.02	60	32	44.5	408	(12) 1/6 size
	SPED60HC-12-4-CL	4	–								402	(12) 1/6 size
	SPED60HC-16-2-CL	2	1/2	115	1/3	5.4	16.02	60	32	44.5	382	(16) 1/6 size
	SPED60HC-16-4-CL	4	–								414	(16) 1/6 size
72"	SPED72HC-08-2-CL	2	2/4	115	1/3	5.4	20.02	72	32	44.5	450	(8) 1/6 size
	SPED72HC-08-4-CL	4	1/2								450	(8) 1/6 size
	SPED72HC-08-6-CL	6	–								456	(8) 1/6 size
	SPED72HC-10-2-CL	2	2/4	115	1/3	5.4	20.02	72	32	44.5	448	(10) 1/6 size
	SPED72HC-10-4-CL	4	1/2								450	(10) 1/6 size
	SPED72HC-10-6-CL	6	–								452	(10) 1/6 size
	SPED72HC-12-2-CL	2	2/4	115	1/3	5.4	20.02	72	32	44.5	418	(12) 1/6 size
	SPED72HC-12-4-CL	4	1/2								442	(12) 1/6 size
	SPED72HC-12-6-CL	6	–								484	(12) 1/6 size
	SPED72HC-18-2-CL	2	2/4	115	1/3	5.4	20.02	72	32	44.5	432	(18) 1/6 size
	SPED72HC-18-4-CL	4	1/2								460	(18) 1/6 size
	SPED72HC-18-6-CL	6	–								484	(18) 1/6 size

For total height, add 3 or 6 inches, based on your mounting choice. Depth measurement includes handles.

SANDWICH PREP

Mega Top

DOORS

MAINTAINS PRODUCT TEMPERATURES OF 36-38°F.

MODEL WIDTH	MODEL #	DOORS/ SHELVES	VOLTS	HP	AMPS	CUBIC FEET	WIDTH	DEPTH	HEIGHT	CRATED WEIGHT	STANDARD PANS 4" DEEP
27" 1 DOOR	SPE27HC-12M-B	1/2	115	1/6	2	6.91	27	38.5	39.25	220	(12) 1/6 size
32" 1 DOOR	SPE32HC-12M	1/2	115	1/6	2	8.01	32	38.5	39.25	246	(12) 1/6 size
36" 2 DOORS	SPE36HC-12M	2/4	115	1/6	2	10.01	36	38.5	39.25	276	(12) 1/6 size
	SPE36HC-15M									274	(15) 1/6 size
48" 2 DOORS	SPE48HC-12M	2/4	115	1/6	2.2	13.01	48	38.5	39.25	336	(12) 1/6 size
	SPE48HC-18M									336	(18) 1/6 size
60" 2 DOORS	SPE60HC-12M	2/4	115	1/3	5.4	16.02	60	38.5	39.25	342	(12) 1/6 size
	SPE60HC-18M									374	(18) 1/6 size
	SPE60HC-24M									392	(24) 1/6 size
72" 3 DOORS	SPE72HC-12M	3/6	115	1/3	5.4	20.02	72	38.5	39.25	432	(12) 1/6 size
	SPE72HC-18M									434	(18) 1/6 size
	SPE72HC-24M									404	(24) 1/6 size
	SPE72HC-30M									446	(30) 1/6 size

MODEL WIDTH	MODEL #	DOORS/ SHELVES	VOLTS	HP	AMPS	CUBIC FEET	WIDTH	DEPTH	HEIGHT	CRATED WEIGHT	STANDARD PANS 4" DEEP
27"	SPE27HC-12M-B-DS	1/2	115	1/6	2	6.91	27	48.75	40.75	244	(12) 1/6
48"	SPE48HC-18M-DS	2/4	115	1/6	2.2	13.01	48	48.75	40.75	376	(18) 1/6 size
60"	SPE60HC-24M-DS	2/4	115	1/3	5.4	16.02	60	48.75	40.75	430	(24) 1/6 size
72"	SPE72HC-30M-DS	3/6	115	1/3	5.4	20.02	72	48.75	40.75	504	(30) 1/6 size

MODEL WIDTH	MODEL #	DOORS/ SHELVES	VOLTS	HP	AMPS	CUBIC FEET	WIDTH	DEPTH	HEIGHT	CRATED WEIGHT	STANDARD PANS 4" DEEP
36"	SPE36HC-15M-STL	2/4	115	1/6	2	10.01	36	38.38	53.75	274	(15) 1/6 size
48"	SPE48HC-18M-STL	2/4	115	1/6	2.2	13.01	48	38.38	53.75	354	(18) 1/6 size
60"	SPE60HC-24M-STL	2/4	115	1/3	5.4	16.02	60	38.38	53.75	414	(24) 1/6 size
72"	SPE72HC-30M-STL	3/6	115	1/3	5.4	20.02	72	38.38	53.75	464	(30) 1/6 size

Depth measurement includes handles.
For total height, add 3 or 6 inches, based on your mounting choice.

DRAWERS

MAINTAINS PRODUCT TEMPERATURES OF 36-38°F.

MODEL WIDTH	MODEL #	DRAWERS	DOORS/ SHELVES	VOLTS	HP	AMPS	CUBIC FEET	WIDTH	DEPTH	HEIGHT	CRATED WEIGHT	STANDARD PANS 4" DEEP
27"	SPED27HC-12M	2	–	115	1/6	2	6.91	27	38.38	39.25	250	(9) 1/6 size & (3) 1/9 size
	SPED27HC-12M-B	2	–								238	(12) 1/6 size
32"	SPED32HC-12M-2	2	–	115	1/6	2	8.01	32	38.5	39.25	280	(12) 1/6 size
36"	SPED36HC-12M-2	2	–	115	1/6	2	10.01	36	38.38	39.25	300	(12) 1/6 size
	SPED36HC-15M-2	2	–								302	(15) 1/6 size
48"	SPED48HC-12M-2	2	1/2	115	1/6	2.2	13.01	48	38.38	39.25	354	(12) 1/6 size
	SPED48HC-12M-4	4	–								360	(12) 1/6 size
	SPED48HC-18M-2	2	1/2	115	1/6	2.2	13.01	48	38.38	39.25	366	(18) 1/6 size
	SPED48HC-18M-4	4	–								394	(18) 1/6 size
60"	SPED60HC-12M-2	2	1/2	115	1/3	5.4	16.02	60	38.38	39.25	390	(12) 1/6 size
	SPED60HC-12M-4	4	–								436	(12) 1/6 size
	SPED60HC-18M-2	2	1/2	115	1/3	5.4	16.02	60	38.38	39.25	406	(18) 1/6 size
	SPED60HC-18M-4	4	–								456	(18) 1/6 size
	SPED60HC-24M-2	2	1/2	115	1/3	5.4	16.02	60	38.38	39.25	424	(24) 1/6 size
	SPED60HC-24M-4	4	–								456	(24) 1/6 size
72"	SPED72HC-12M-2	2	2/4	115	1/3	5.4	20.02	72	38.38	39.25	482	(12) 1/6 size
	SPED72HC-12M-4	4	1/2								484	(12) 1/6 size
	SPED72HC-12M-6	6	–								484	(12) 1/6 size
	SPED72HC-18M-2	2	2/4	115	1/3	5.4	20.02	72	38.38	39.25	450	(18) 1/6 size
	SPED72HC-18M-4	4	1/2								450	(18) 1/6 size
	SPED72HC-18M-6	6	–								505	(18) 1/6 size
	SPED72HC-24M-2	2	2/4	115	1/3	5.4	20.02	72	38.38	39.25	470	(24) 1/6 size
	SPED72HC-24M-4	4	1/2								492	(24) 1/6 size
	SPED72HC-24M-6	6	–								496	(24) 1/6 size
	SPED72HC-30M-2	2	2/4	115	1/3	5.4	20.02	72	38.38	39.25	480	(30) 1/6 size
	SPED72HC-30M-4	4	1/2								508	(30) 1/6 size
	SPED72HC-30M-6	6	–								528	(30) 1/6 size

Depth measurement includes handles.
For total height, add 3 or 6 inches, based on your mounting choice.

SANDWICH PREP

Clear Lid Mega Top

DOORS

MAINTAINS PRODUCT TEMPERATURES OF 36-38°F.

MODEL WIDTH	MODEL #	DOORS/ SHELVES	VOLTS	HP	AMPS	CUBIC FEET	WIDTH	DEPTH	HEIGHT	CRATED WEIGHT	STANDARD PANS 4" DEEP
27" 1 DOOR	SPE27HC-12M-B-CL	1/2	115	1/6	2	6.91	27	38.5	50.75	220	(12) 1/6 size
32" 1 DOOR	SPE32HC-12M-CL	1/2	115	1/6	2	8.01	32	38.5	50.75	246	(12) 1/6 size
36" 2 DOORS	SPE36HC-12M-CL	2/4	115	1/6	2	10.01	36	38.5	50.75	276	(12) 1/6 size
	SPE36HC-15M-CL									274	(15) 1/6 size
48" 2 DOORS	SPE48HC-12M-CL	2/4	115	1/6	2.2	13.01	48	38.5	50.75	336	(12) 1/6 size
	SPE48HC-18M-CL									336	(18) 1/6 size
60" 2 DOORS	SPE60HC-12M-CL	2/4	115	1/3	5.4	16.02	60	38.5	50.75	342	(12) 1/6 size
	SPE60HC-18M-CL									374	(18) 1/6 size
	SPE60HC-24M-CL									392	(24) 1/6 size
72" 3 DOORS	SPE72HC-12M-CL	3/6	115	1/3	5.4	20.02	72	38.5	50.75	432	(12) 1/6 size
	SPE72HC-18M-CL									434	(18) 1/6 size
	SPE72HC-24M-CL									404	(24) 1/6 size
	SPE72HC-30M-CL									446	(30) 1/6 size

NEW

*Depth measurement includes handles.
For total height, add 3 or 6 inches, based on your mounting choice.*

AVAILABLE OPTIONS	
SUFFIX	OPTION
24	Left hand hinge doors
R	Remote models available
Append suffix to model # when placing order	

CLEAR LIDS



DRAWERS

MAINTAINS PRODUCT TEMPERATURES OF 36-38°F.

MODEL WIDTH	MODEL #	DRAWERS	DOORS/ SHELVES	VOLTS	HP	AMPS	CUBIC FEET	WIDTH	DEPTH	HEIGHT	CRATED WEIGHT	STANDARD PANS 4" DEEP
27"	SPED27HC-12M-CL	2	–	115	1/6	2	6.91	27	38.38	50.75	250	(9) 1/6 size & (3) 1/9 size
	SPED27HC-12M-B-CL	2	–								238	(12) 1/6 size
32"	SPED32HC-12M-2-CL	2	–	115	1/6	2	8.01	32	38.5	50.75	280	(12) 1/6 size
36"	SPED36HC-12M-2-CL	2	–	115	1/6	2	10.01	36	38.38	50.75	300	(12) 1/6 size
	SPED36HC-15M-2-CL	2	–								302	(15) 1/6 size
48"	SPED48HC-12M-2-CL	2	1/2	115	1/6	2.2	13.01	48	38.38	50.75	354	(12) 1/6 size
	SPED48HC-12M-4-CL	4	–								360	(12) 1/6 size
	SPED48HC-18M-2-CL	2	1/2	115	1/6	2.2	13.01	48	38.38	50.75	366	(18) 1/6 size
	SPED48HC-18M-4-CL	4	–								394	(18) 1/6 size
60"	SPED60HC-12M-2-CL	2	1/2	115	1/3	5.4	16.02	60	38.38	50.75	390	(12) 1/6 size
	SPED60HC-12M-4-CL	4	–								436	(12) 1/6 size
	SPED60HC-18M-2-CL	2	1/2	115	1/3	5.4	16.02	60	38.38	50.75	406	(18) 1/6 size
	SPED60HC-18M-4-CL	4	–								456	(18) 1/6 size
	SPED60HC-24M-2-CL	2	1/2	115	1/3	5.4	16.02	60	38.38	50.75	414	(24) 1/6 size
	SPED60HC-24M-4-CL	4	–								456	(24) 1/6 size
72"	SPED72HC-12M-2-CL	2	2/4	115	1/3	5.4	20.02	72	38.38	50.75	482	(12) 1/6 size
	SPED72HC-12M-4-CL	4	1/2								484	(12) 1/6 size
	SPED72HC-12M-6-CL	6	–								484	(12) 1/6 size
	SPED72HC-18M-2-CL	2	2/4	115	1/3	5.4	20.02	72	38.38	50.75	450	(18) 1/6 size
	SPED72HC-18M-4-CL	4	1/2								450	(18) 1/6 size
	SPED72HC-18M-6-CL	6	–								505	(18) 1/6 size
	SPED72HC-24M-2-CL	2	2/4	115	1/3	5.4	20.02	72	38.38	50.75	470	(24) 1/6 size
	SPED72HC-24M-4-CL	4	1/2								492	(24) 1/6 size
	SPED72HC-24M-6-CL	6	–								496	(24) 1/6 size
	SPED72HC-30M-2-CL	2	2/4	115	1/3	5.4	20.02	72	38.38	50.75	480	(30) 1/6 size
	SPED72HC-30M-4-CL	4	1/2								508	(30) 1/6 size
	SPED72HC-30M-6-CL	6	–								528	(30) 1/6 size

NEW

Depth measurement includes handles.
For total height, add 3 or 6 inches, based on your mounting choice.

SANDWICH PREP

Cutting Top

17" DEEP REVERSIBLE CUTTING BOARD

DOORS

MAINTAINS PRODUCT TEMPERATURES OF 36-38°F.

MODEL WIDTH	MODEL #	DOORS/SHELVES	VOLTS	HP	AMPS	CUBIC FEET	WIDTH	DEPTH	HEIGHT	CRATED WEIGHT	STANDARD PANS 4" DEEP
27" 1 DOOR	SPE27HC-C	1/2	115	1/6	2	6.91	27	38.38	39.25	212	(6) 1/6 size & (2) 1/9 size
	SPE27HC-C-B									212	(8) 1/6 size
36" 2 DOORS	SPE36HC-08C	2/4	115	1/6	2	10.01	36	38.38	39.25	268	(8) 1/6 size
	SPE36HC-10C									276	(10) 1/6 size
48" 2 DOORS	SPE48HC-08C	2/4	115	1/6	2.2	13.01	48	38.38	39.25	326	(8) 1/6 size
	SPE48HC-10C									322	(10) 1/6 size
	SPE48HC-12C									326	(12) 1/6 size
60" 2 DOORS	SPE60HC-08C	2/4	115	1/3	5.4	16.02	60	38.38	39.25	332	(8) 1/6 size
	SPE60HC-10C									334	(10) 1/6 size
	SPE60HC-12C									342	(12) 1/6 size
	SPE60HC-16C									376	(16) 1/6 size
72" 3 DOORS	SPE72HC-08C	3/6	115	1/3	5.4	20.02	72	38.38	39.25	396	(8) 1/6 size
	SPE72HC-10C									427	(10) 1/6 size
	SPE72HC-12C									420	(12) 1/6 size
	SPE72HC-18C									438	(18) 1/6 size

Depth measurement includes handles.
For total height, add 3 or 6 inches, based on your mounting choice.

AVAILABLE OPTIONS

SUFFIX	OPTION
24	Left hand hinge doors
R	Remote models available
Append suffix to model # when placing order	

DRAWER PAN CONFIGURATIONS for all SPED units

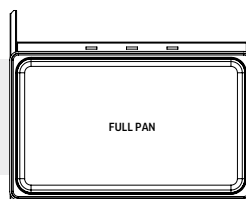

SPE027 / SPE032 / SPE060

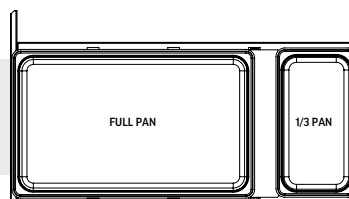

SPE036

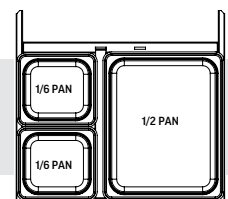

SPE048 / SPE072

DRAWERS

MAINTAINS PRODUCT TEMPERATURES OF 36-38°F.

MODEL WIDTH	MODEL #	DRAWERS	DOORS/ SHELVES	VOLTS	HP	AMPS	CUBIC FEET	WIDTH	DEPTH	HEIGHT	CRATED WEIGHT	STANDARD PANS 4" DEEP
27"	SPED27HC-C	2	–	115	1/6	2	6.91	27	38.38	39.25	238	(6) 1/6 size & (2) 1/9 size
	SPED27HC-C-B	2	–								238	(8) 1/6 size
36"	SPED36HC-08C-2	2	–	115	1/6	2	10.01	36	38.38	39.25	276	(8) 1/6 size
	SPED36HC-10C-2	2	–								278	(10) 1/6 size
48"	SPED48HC-08C-2	2	1/2	115	1/6	2.2	13.01	48	38.38	39.25	358	(8) 1/6 size
	SPED48HC-08C-4	4	–								358	(8) 1/6 size
	SPED48HC-10C-2	2	1/2	115	1/6	2.2	13.01	48	38.38	39.25	326	(10) 1/6 size
	SPED48HC-10C-4	4	–								326	(10) 1/6 size
	SPED48HC-12C-2	2	1/2	115	1/6	2.2	13.01	48	38.38	39.25	348	(12) 1/6 size
	SPED48HC-12C-4	4	–								380	(12) 1/6 size
60"	SPED60HC-08C-2	2	1/2	115	1/3	5.4	16.02	60	38.38	39.25	404	(8) 1/6 size
	SPED60HC-08C-4	4	–								404	(8) 1/6 size
	SPED60HC-10C-2	2	1/2	115	1/3	5.4	16.02	60	38.38	39.25	406	(10) 1/6 size
	SPED60HC-10C-4	4	–								406	(10) 1/6 size
	SPED60HC-12C-2	2	1/2	115	1/3	5.4	16.02	60	38.38	39.25	402	(12) 1/6 size
	SPED60HC-12C-4	4	–								368	(12) 1/6 size
	SPED60HC-16C-2	2	1/2	115	1/3	5.4	16.02	60	38.38	39.25	420	(16) 1/6 size
	SPED60HC-16C-4	4	–								456	(16) 1/6 size
72"	SPED72HC-08C-2	2	2/4	115	1/3	5.4	20.02	72	38.38	39.25	450	(8) 1/6 size
	SPED72HC-08C-4	4	1/2								454	(8) 1/6 size
	SPED72HC-08C-6	6	–								456	(8) 1/6 size
	SPED72HC-10C-2	2	2/4	115	1/3	5.4	20.02	72	38.38	39.25	448	(10) 1/6 size
	SPED72HC-10C-4	4	1/2								450	(10) 1/6 size
	SPED72HC-10C-6	6	–								452	(10) 1/6 size
	SPED72HC-12C-2	2	2/4	115	1/3	5.4	20.02	72	38.38	39.25	418	(12) 1/6 size
	SPED72HC-12C-4	4	1/2								442	(12) 1/6 size
	SPED72HC-12C-6	6	–								508	(12) 1/6 size
	SPED72HC-18C-2	2	2/4	115	1/3	5.4	20.02	72	38.38	39.25	468	(18) 1/6 size
	SPED72HC-18C-4	4	1/2								486	(18) 1/6 size
	SPED72HC-18C-6	6	–								538	(18) 1/6 size

Depth measurement includes handles.
For total height, add 3 or 6 inches, based on your mounting choice.

SANDWICH PREP

Pan Configurations

Standard Top

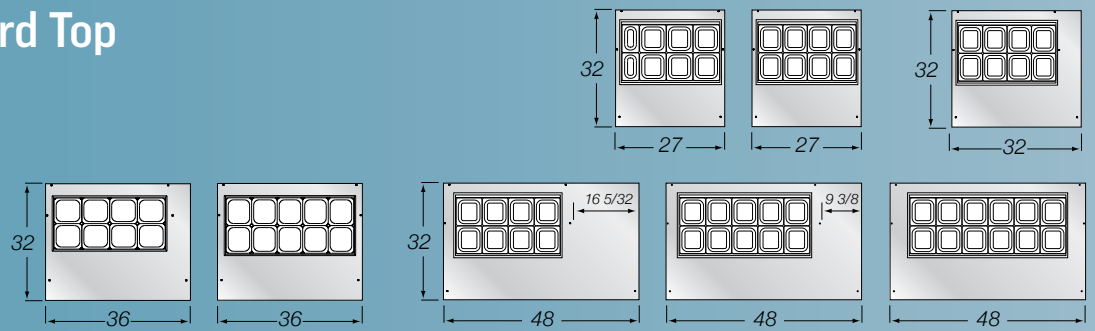

Mega Top

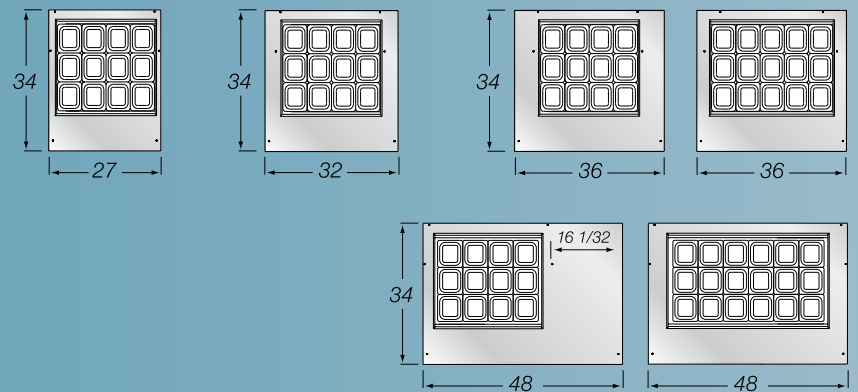

Cutting Top

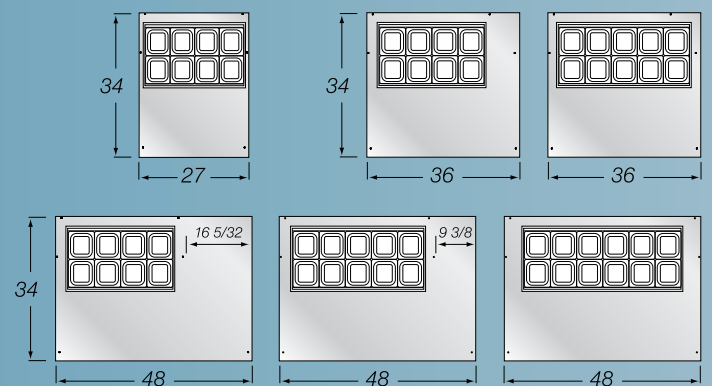

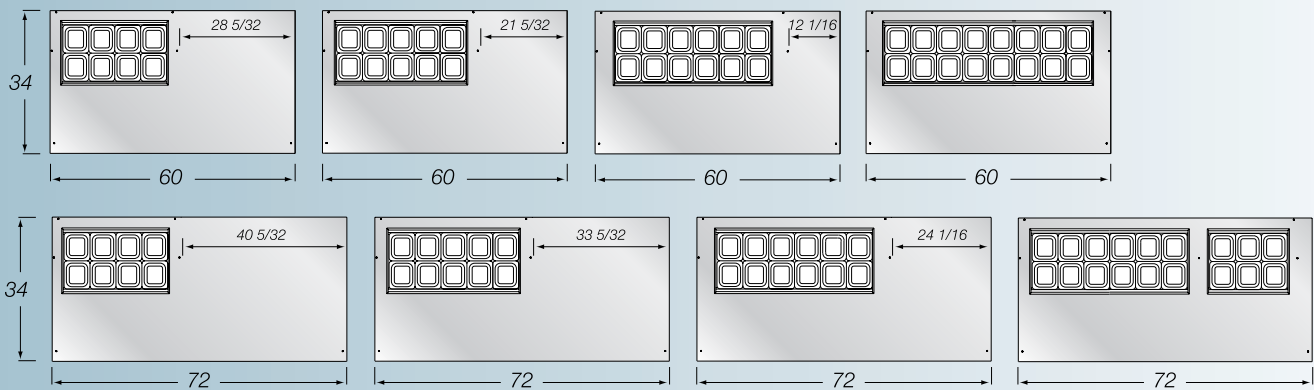
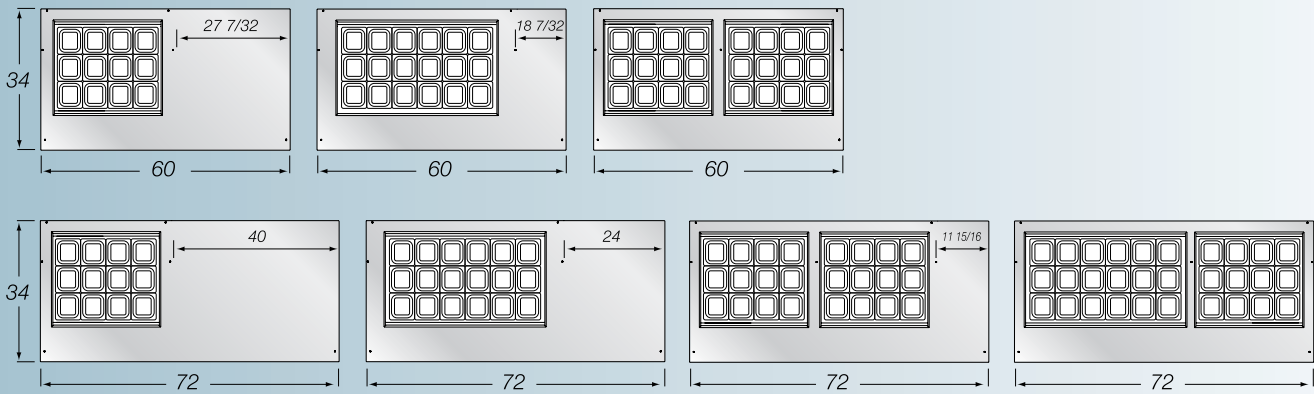
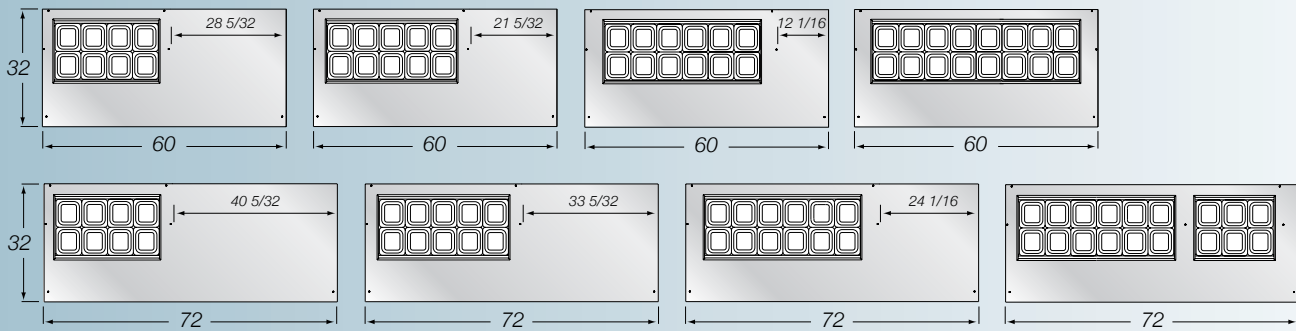

PIZZA PREP

New duct system features uniform airflow distribution
over evaporator coil and throughout raised rail

Newly designed easy-open lid system
provides easier accessibility

Electronic controller with smart-defrost

12-Gauge stainless steel drawer slides
with Delrin® rollers rated at 275 lbs

Electrical defrost heater
terminates defrost sooner, reducing product instability

Right or left compressor placement
specify at time of order

Field reversible doors
with 120 degree stay open feature

Heavy-duty aluminum pan liner
is easy to clean and prevents spills from falling into cabinet

Accommodates up to 6" deep food service pans
Not included

Improved serviceability
Removable service panel for easy access to refrigeration system

Featuring environmentally friendly
energy efficient R290 refrigerant



DESIGNED TO PERFORM IN HIGH AMBIENT CONDITIONS
LOW-PROFILE DESIGN FOR ENHANCED ERGONOMICS AND PRODUCT DISPLAY
IMPROVED AIRFLOW MAINTAINS CONSISTENT PAN TEMPERATURE IN TOP RAIL



3 DRAWERS IN SINGLE SECTION
available on all sizes



CLEAR LIDS AVAILABLE
for optimized product display

ACCESS OPTIONS

- Doors
- Drawers (stacks of 2 or 3)

LID OPTIONS

- Clear lids
- Flat Lift-off lids

AGENCY CERTIFICATIONS



Pizza & Deli Prep Tables



EXTERIOR FINISHES

- Stainless steel with galvanized back
- Stainless steel with stainless back

INTERIOR FINISHES

- Corrosion-resistant aluminum
- Stainless

AVAILABLE ACCESSORIES

- Composite cutting boards
- Bun tray racks
- Overshelf
- Locks
- Additional shelves
- Pan slides (18x26)



AVAILABLE OPTIONS

- Left hand hinge doors
- Remote models available
- Alternate compressor locations

MOUNTING OPTIONS

- 3" casters (standard)
- 6" casters
- 6" legs

PIZZA PREP

DOORS

MAINTAINS PRODUCT TEMPERATURES OF 36-38°F.

MODEL WIDTH	MODEL #	DOORS/SHELVES	VOLTS	HP	AMPS	CUBIC FEET	WIDTH	DEPTH	HEIGHT	CRATED WEIGHT	FULL SIZE PAN CAPACITY
46"	DP46HC	1/2	115	1/3	4.5	11.91	46	37	49.75	336	2
60"	DP60HC	2/4	115	1/3	4.5	17	60	37	49.75	440	3 & 1 half
67"	DP67HC	2/4	115	1/3	4.5	20.68	67	37	49.75	440	3
72"	DP72HC	2/4	115	1/3	4.5	21.87	72	37	49.75	438	3
93"	DP93HC	3/6	115	1/2	7.8	31.54	93	37	49.75	574	4
119"	DP119HC	4/8	115	1/2	7.8	42.2	119	37	49.75	712	5 & 1 third

NEW

NEW

*Depth measurement includes cutting board.
For total height, add 3 or 6 inches, based on your mounting choice.*



DPD72HC-3 (see page 90)

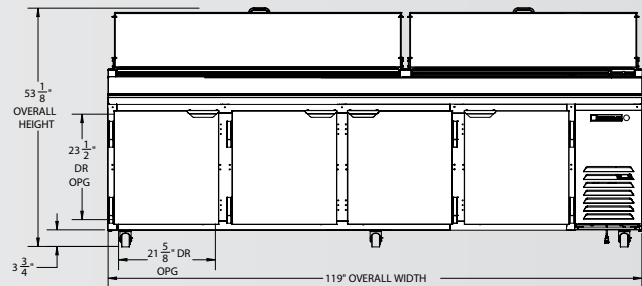
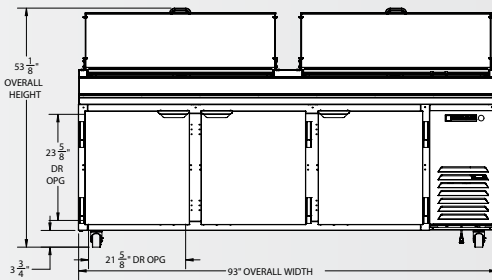
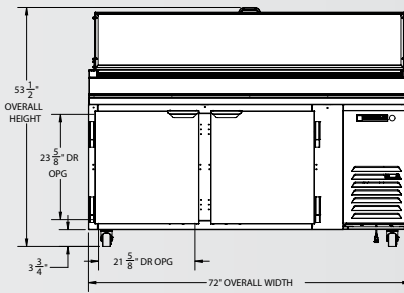
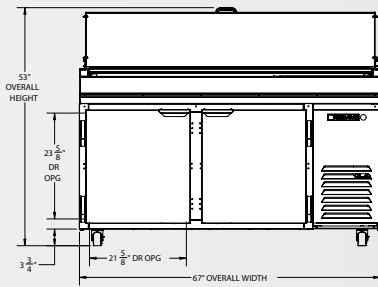
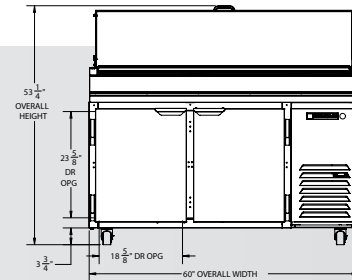
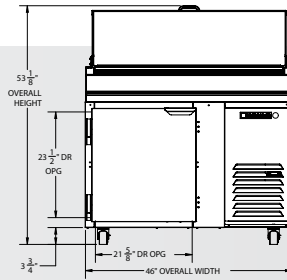
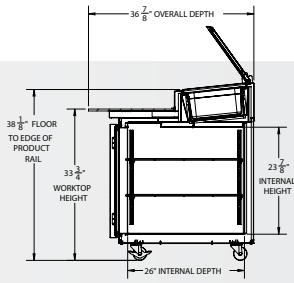

PAN CONFIGURATIONS
for DP and DPD units

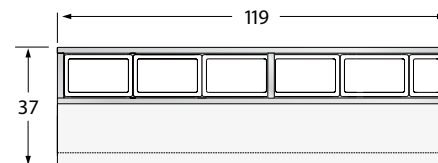
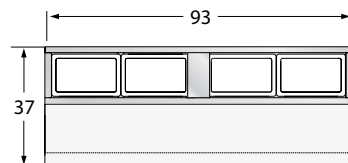
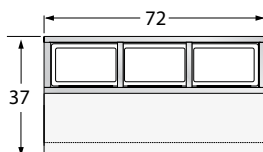
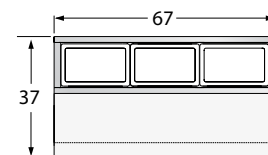
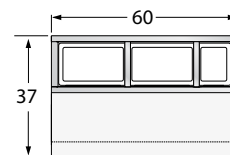
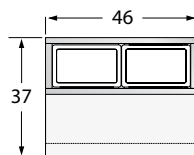

PIZZA PREP

DRAWERS

MAINTAINS PRODUCT TEMPERATURES OF 36-38°F.

MODEL WIDTH	MODEL #	DRAWERS	DOORS/SHELVES	VOLTS	HP	AMPS	CUBIC FEET	WIDTH	DEPTH	HEIGHT	CRATED WEIGHT	FULL SIZE PAN CAPACITY
46"	DPD46HC-2	2	-	115	1/3	4.5	11.91	46	37	49.75	311	2
	DPD46HC-3	3										
60"	DPD60HC-2	2	-	115	1/3	4.5	17	60	37	49.75	454	3 & 1 half
	DPD60HC-3	3										
67"	DPD67HC-2	2	1/2	115	1/3	4.5	20.68	67	37	49.75	484	3
	DPD67HC-3	3										
	DPD67HC-4	4	-									
	DPD67HC-6	6										
72"	DPD72HC-2	2	1/2	115	1/3	4.5	21.87	72	37	49.75	540	3
	DPD72HC-3	3										
	DPD72HC-4	4	-									
	DPD72HC-6	6										
93"	DPD93HC-2	2	2/4	115	1/2	7.8	31.54	93	37	49.75	600	4
	DPD93HC-3	3										
	DPD93HC-4	4	1/2									
	DPD93HC-6	6	-									
119"	DPD119HC-2	2	3/6	115	1/2	7.8	42.2	119	37	49.75	703	5 & 1 third
	DPD119HC-3	3	3/6									
	DPD119HC-4	4	2/4									
	DPD119HC-6	6	1/2									
	DPD119HC-6T	6	2/4									
	DPD119HC-8	8	-									
	DPD119HC-9	9	1/2									

Depth measurement includes handles. For total height, add 3 or 6 inches, based on your mounting choice.

DRAWER PAN CONFIGURATIONS for DPD units

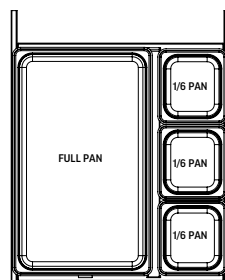

DPD46 / DPD67 / DPD72 / DPD93 / DPD119

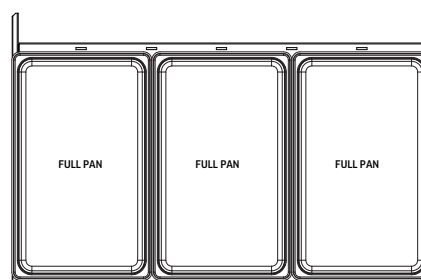

DPD60

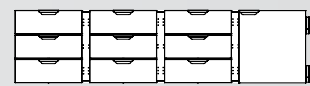
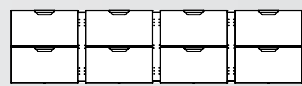
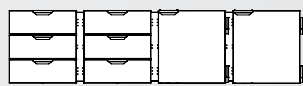
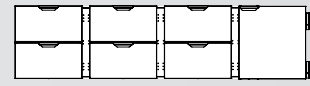
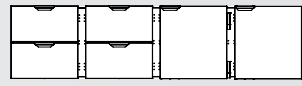
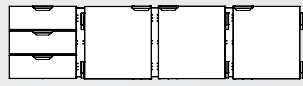
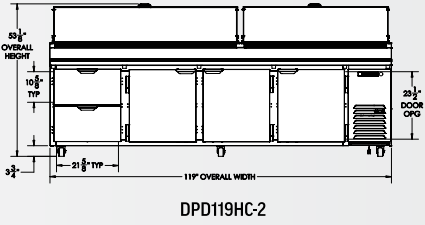
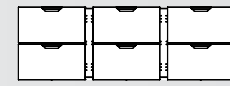
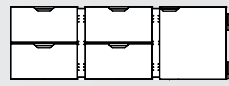
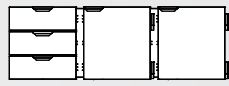
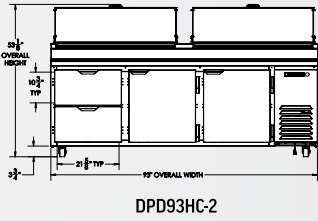
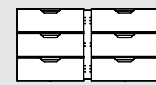
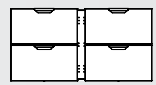
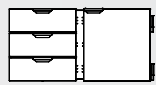
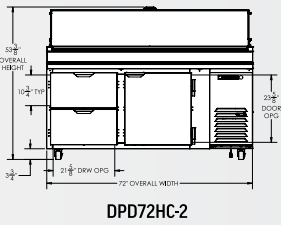
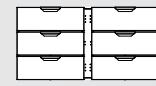
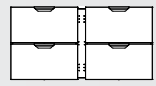
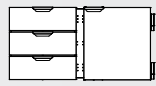
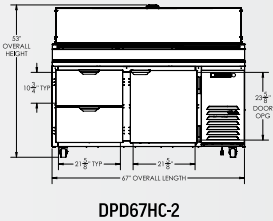
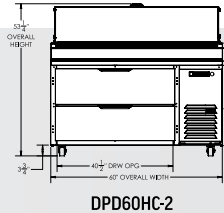
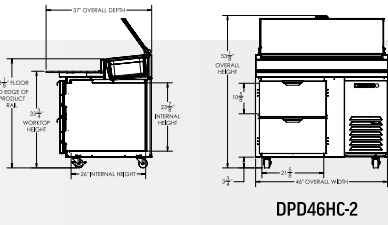

SALAD BARS

NEW

Locking divider bars

Lift-off lids standard

to help maintain product temperature

Heavy-duty aluminum pan liner

Easy to clean and prevents spills from falling into cabinet while also ensuring coldest air flows across bottom of pans

Field reversible doors with 120 degree stay-open feature

Two epoxy coated shelves per door section standard

Snap-in door gaskets

Accommodates up to 6" deep food service pans

4" deep 1/3 size polycarbonate pans are included

6" heavy duty casters standard

3" casters or 6" leg option available at no charge when specified on order

AVAILABLE ACCESSORIES

- Foldable tray slides for single or dual-sided service
- Dual-sided sneeze guard, with optional add on for single side service



DESIGNED TO PERFORM IN HIGH AMBIENT CONDITIONS

3 YEAR PARTS & LABOR WARRANTY WITH AN ADDITIONAL 4 YEAR COMPRESSOR WARRANTY

MADE IN USA



PERFECT SEAL PAN LINER
ensures airflow under pans and protects bottom of cabinet from pan spills



LIFT-OFF LIDS STANDARD
to help maintain product temperature

ACCESS OPTIONS

- Doors

AGENCY CERTIFICATIONS



SALAD BARS

MAINTAINS PRODUCT TEMPERATURES OF 36-38°F.

APPROXIMATE MODEL WIDTH	MODEL #	DOORS/SHELVES	VOLTS	HP	AMPS	CUBIC FEET	WIDTH	DEPTH	HEIGHT	STANDARD PANS 4" DEEP
36"	SPE36HC-S	2/4	115	1/6	2	10	36	30.13	30.88	(6) 1/3 size
48"	SPE48HC-S	2/4	115	1/6	2.2	13	48	30.13	30.88	(9) 1/3 size
60"	SPE60HC-S	2/4	115	1/3	5.4	16	60	30.13	30.88	(12) 1/3 size
72"	SPE72HC-S	3/6	115	1/3	5.4	20	72	30.13	30.88	(15) 1/3 size

For total height, add 3 or 6 inches, based on your mounting choice. Depth measurement includes handles.



EXTERIOR FINISHES

- Stainless steel with stainless back

INTERIOR FINISHES

- Corrosion-resistant aluminum
- Stainless steel

AVAILABLE ACCESSORIES

- Foldable tray slides for single or dual-sided service
- Dual-sided sneeze guard, with optional add on for single side service
- Locks

AVAILABLE OPTIONS

- Left hand hinge doors
- Remote models available

LID OPTIONS

- Lift-Off Lids

MOUNTING OPTIONS

- 6" casters
- 3" casters (allows for ADA compliant working height)
- 6" legs

Food Prep Table Accessories

DESCRIPTION	UNIT(S)	PART NUMBER
SHELVING / ORGANIZERS		
Epoxy Coated Wire Shelf (Large)	SPE27/27-12M/27C	403-826B
Epoxy Coated Wire Shelf (Small)	SPE27/SPE27-12M/SPE27C	403-912D-01
Epoxy Coated Wire Shelf (Large)	SPE36/SPE36M/SPE36C	403-911D-01
Epoxy Coated Wire Shelf (Small)	SPE36/SPE36M/SPE36C	403-915D-01
Epoxy Coated Wire Shelf (Large)	SPE48/48M/48C	403-828B
Epoxy Coated Wire Shelf (Small)	SPE48/SPE48M/SPE48C	403-913D-01
Epoxy Coated Wire Shelf (Large)	SPE60/60M/60C	403-829B
Epoxy Coated Wire Shelf (Small)	SPE60/SPE60M/SPE60C	403-914D-01
Epoxy Coated Ctr Section Wire Shelf (Large)	SPE72/72M/72C	403-827B
Epoxy Coated Wire Shelf L&R (Large)	SPE72/72M/72C	403-828B
Epoxy Coated Ctr Section Wire Shelf (Small)	SPE72/SPE72M/SPE72C	403-912D-01
Epoxy Coated Wire Shelf L&R (Small)	SPE72/SPE72M/SPE72C	403-913D-01
Shelf Clip	All SPE/SPED/DP/DPD	403-169A
Large Wire Shelf Divider	SPE27	403-722C
Small Wire Shelf Divider	SPE27	403-721C
Large Wire Shelf Divider	SPE36	403-723C
Small Wire Shelf Divider	SPE36	403-721C
Large Wire Shelf Divider	SPE48	403-723C
Small Wire Shelf Divider	SPE48	403-721C
Large Wire Shelf Divider	SPE60	403-723C
Small Wire Shelf Divider	SPE60	403-721C
Large Wire Shelf Divider	SPE72	403-723C
Small Wire Shelf Divider	SPE72	403-721C
Bottle Organizer (Holds Qty. 10 Bottles) 16 oz.	SPE Mega Tops	00B23-023D-01
Bottle Organizer (Holds Qty. 10 Bottles) 24 oz.	SPE Mega Tops	00B23-024D-01
Bottle Organizer (Holds Qty. 8 Bottles) 16 oz.	SPE Standard & Cutting Tops	00B23-025D-01
Bottle Organizer (Holds Qty. 6 Bottles) 24 oz.	SPE Standard & Cutting Tops	00B23-026D-01
CRUMBCATCHERS		
Crumbcatcher Kit	SPE27A/SPE27B/SPE27MA/SPE27MB	00C23-071A-01
Crumbcatcher Kit	SPE36/36M	00C23-071A-09
Crumbcatcher Kit	SPE48/48M	00C23-071A-02
Crumbcatcher Kit	SPE60/60M	00C23-071A-03
Crumbcatcher Kit	SPE72/72M	00C23-071A-04
Crumbcatcher Kit	SPE27C	00C23-071A-05
Crumbcatcher Kit	SPE36C	00C23-071A-10
Crumbcatcher Kit	SPE48C	00C23-071A-06
Crumbcatcher Kit	SPE60C	00C23-071A-07
Crumbcatcher Kit	SPE72C	00C23-071A-08
Side Crumbcatcher Kit	SPE Series	00C23-072A
TRAY SLIDES & PAN INSERTS		
Pan Insert	SPE27A	00B23-032D-01
Pan Insert	SPE27B	00B32-033D-01

DESCRIPTION	UNIT(S)	PART NUMBER
SPE WHITE POLY CUTTING BOARDS		
10" Cutting Board	SPE27/27-12M, SPED27	705-290C-01
10" Cutting Board	SPE36/SPE36 MEGA/SPED36	705-290C-05
10" Cutting Board	SPE48/48M, SPED48	705-290C-02
10" Cutting Board	SPE60/60M, SPED60	705-290C-03
10" Cutting Board	SPE72/72M, SPED72	705-290C-04
17" Cutting Board	SPE27C, SPED27C	705-264C
17" Cutting Board	SPE32C, SPED32C	705-414D-02
17" Cutting Board	SPE36C/SPED36C	705-414D-01
17" Cutting Board	SPE48C, SPED48C	705-265C
17" Cutting Board	SPE60C, SPED60C	705-266C
17" Cutting Board	SPE72C, SPED72C	705-267C

DP WHITE POLY CUTTING BOARDS (1/2" THICK)		
19" Cutting Board	DP46	705-307C-01
19" Cutting Board	DP67	705-286B
19" Cutting Board	DP93	705-287B
19" Cutting Board	DP119	705-288B

SPE COMPOSITE CUTTING BOARDS (1/2" THICK)		
10" Composite Cutting Board	SPE27M	705-392D-06
17" Composite Cutting Board	SPE27C	705-392D-07
10" Composite Cutting Board	SPE36A	705-392D-15
10" Composite Cutting Board	SPE48	705-392D-04
12" Composite Cutting Board	SPE48	705-378B-01
15" Composite Cutting Board	SPE48C	705-392D-01
17" Composite Cutting Board	SPE48C	705-392D-08
10" Composite Cutting Board	SPE60	705-392D-05
15" Composite Cutting Board	SPE60C	705-392D-02
17" Composite Cutting Board	SPE60C	705-392D-09
10" Composite Cutting Board	SPE72	705-378B-02
17" Composite Cutting Board	SPE72C	705-392D-10

DP COMPOSITE CUTTING BOARDS (1/2" THICK)		
19" X 46" Composite Cutting Board	DP46	705-392D-11
19" X 67" Composite Cutting Board	DP67	705-392D-12
19" X 93" Composite Cutting Board	DP93	705-392D-13
19" X 119" Composite Cutting Board	DP119	705-392D-14

Food Prep Table Accessories

DESCRIPTION	UNIT(S)	PART NUMBER
OVERSHELVES		
10" Single	SPE27	00C23S026A
10" Single	SPE36-08	00C23-074A-11
10" Single	SPE36-10	00C23-074A-12
10" Single	SPE48	00C23-027A
10" Single	SPE60	00C23-028A
10" Single	SPE72	00C23-029A
10" Double	SPE27	00C23-030A
10" Double	SPE36-08	00C23-075A-08
10" Double	SPE36-10	00C23-075A-09
10" Double	SPE48	00C23-031A
10" Double	SPE60	00C23-032A
10" Double	SPE72	00C23-033A
Single	SPE27-12M	00C23-074A-01
Single	SPE32-12M	00C23-074A-02
Single	SPE36-12M	00C23-074A-10
Single	SPE36-15M	00C23-074A-12
Single	SPE48/60/72-12M	00C23-074A-02
Single	SPE48-18M	00C23-074A-03
Single / For Dual-Sided	SPE48-18M-DS	00C23-105D
Single	SPE60-18M	00C23-074A-04
Single	SPE60-24M	00C23-074A-05
Single / For Dual-Sided	SPE60-24M-DS	00C23-106D
Single	SPE72-18M	00C23-074A-06
Single	SPE72-24M	00C23-074A-07
Single	SPE72-30M	00C23-074A-08
Single / For Dual-Sided	SPE72-30M-DS	00C23-093A
Double	SPE27-12M	00C23-030A
Double	SPE27-12M-B	00C23-075A-06
Double	SPE36-12M	00C23-075A-8
Double	SPE36-15M	00C23-075A-09
Double	SPE48-12M	00C23-075A-01
Double / For Dual-Sided	SPE48-18M-DS	00C23-107D-02
Double	SPE60-12M	00C23-075A-01
Double	SPE72-12M	00C23-075A-01
Double	SPE48-18M	00C23-075A-02
Double	SPE60-18M	00C23-075A-03
Double	SPE60-24M	00C23-075A-04
Double / For Dual-Sided	SPE60-24M-DS	00C23-107D-03
Double	SPE72-24M	00C23-032A
Double	SPE72-30M	00C23-075A-05
Double / For Dual-Sided	SPE72-30M-DS	00C23-107D-04
Single - 14" Deep	DP46	00C23-044A
Single - 14" Deep	DP60	00C23-161D-01
Single - 14" Deep	DP67	00C23-045A
Single - 14" Deep	DP72	00C23-161D-03
Single - 14" Deep	DP93	00C23-046A
Single - 14" Deep	DP119	00C23-161D-05

Clear-lid models (-CL) of SPE and SPED units cannot have an overshelf

DESCRIPTION	UNIT(S)	PART NUMBER
OVERSHELVES CONT'D		
Double - 14" Deep	DP46	00C23-119D-01
Double - 14" Deep	DP60	00C23-161D-02
Double - 14" Deep	DP67	00C23-116D-01
Double - 14" Deep	DP72	00C23-161D-04
Double - 14" Deep	DP93	00C23-120D-00
Double - 14" Deep	DP119	00C23-161D-06
Single - 14" Deep	SPE36-15M-STL	00C23-110D
Single - 14" Deep	SPE48-18M-STL	00C23-094D
Single - 14" Deep	SPE60-24M-STL	00C23-095D
Single - 14" Deep	SPE72-30M-STL	00C23-096D
Single - 14" Deep with side guards & LED light	SPE48-18M-STL	00C23-113D-01
Single - 14" Deep with side guards & LED light	SPE60-24M-STL	00C23-113D-02
Single - 14" Deep with side guards & LED light	SPE72-30M-STL	00C23-113D-03
Double - 10" Deep	SPE27 (will not work on B top)	00C23-123D-00
Double - 10" Deep	SPE36	00C23-124D-00
Double - 10" Deep	SPE48	00C23-125D-00
Double - 10" Deep	SPE60	00C23-126D-00
Double - 10" Deep	SPE72	00C23-127D-00
Double - 18" Deep	SPE27-M (will not fit on B top)	00C23-128D-00
Double - 18" Deep	SPE36-M	00C23-129D-00
Double - 18" Deep	SPE48-M	00C23-130D-00
Double - 18" Deep	SPE60-M	00C23-131D-00
Double - 18" Deep	SPE72-M	00C23-132D-00

Clear-lid models (-CL) of SPE and SPED units cannot have an overshelf

ADDITIONAL ACCESSORIES		
Door Lock	DP, SPE (per door)	00C30-099A

MOUNTING		
3" Caster	SPE units (set of four)	00C31-041A
6" Caster	SPE units (set of four)	00C31-038A
3" Caster	DP46,67,93 (set of four)	61C01-013A
6" Caster	DP46,67,93 (set of four)	61C01-001A
3" Caster	DP119 (set of six)	61C01-012A
6" Black Leg	SPE units (set of four)	58B02S001A
6" Black Leg	DP46,67,93 (set of four)	58B02S001A
6" Black Leg	DP119 (set of six)	58B02S002A
6" Seismic/Flanged Legs	SPE Series (set of four)	00C31-055A
6" Seismic/Flanged Legs	DP Series (set of four)	00C31-055A
2 3/4 in Caster Kit	Low Profile (set of four) SPE	00C31-049A
2" Roller Kit	SPE units	00C31S045A

Food Prep Table Accessories

UNIT(S)		DESCRIPTION	PART NUMBER
---------	--	-------------	-------------

NIGHT COVERS FOR STANDARD PREP	COVERS REQUIRED	DESCRIPTION	PART NUMBER
SPE27HCHC	1	8 pan cover	00C32-013A-02
SPE32HCHC-08	1	8 pan cover	00C32-013A-06
SPE36HC-08	1	8 pan cover	00C32-013A-06
SPE36HC-10	1	10 pan cover	00C32-013A-07
SPE48HC-08	1	8 pan cover	00C32-013A-02
SPE48HC-10	1	10 pan cover	00C32-013A-03
SPE48HC-12	1	12 pan cover	00C32-013A-04
SPE60HC-08	1	8 pan cover	00C32-013A-02
SPE60HC-10	1	10 pan cover	00C32-013A-03
SPE60HC-12	1	12 pan cover	00C32-013A-04
SPE60HC-16	1	16 pan cover	00C32-013A-05
SPE72HC-08	1	8 pan cover	00C32-013A-02
SPE72HC-10	1	10 pan cover	00C32-013A-03
SPE72HC-12	1	12 pan cover	00C32-013A-04
SPE72HC-18	2	12 pan cover	00C32-013A-04
		6 pan cover	00C32-013A-01

NIGHT COVERS FOR MEGATOP PREP	COVERS REQUIRED	DESCRIPTION	PART NUMBER
SPE27HC-12M	1	12 pan cover	00C32-014A-03
SPE32HC-12M	1	12 pan cover	00C32-014A-01
SPE36HC-12M	1	12 pan cover	00C32-014A-01
SPE36HC-15M	1	15 pan cover	00C32-014A-04
SPE48HC-12M	1	12 pan cover	00C32-014A-01
SPE48HC-18M	1	18 pan cover	00C32-014A-02
SPE60HC-12M	1	12 pan cover	00C32-014A-01
SPE60HC-18M	1	18 pan cover	00C32-014A-02
SPE60HC-24M	2	12 pan cover (order two)	00C32-014A-01
SPE72HC-12M	1	12 pan cover	00C32-014A-01
SPE72HC-18M	1	18 pan cover	00C32-014A-02
SPE72HC-24M	2	12 pan cover (order two)	00C32-014A-01
SPE72HC-30M	2	12 pan cover	00C32-014A-01
		18 pan cover	00C32-014A-02

NIGHT COVERS FOR PIZZA PREP	COVERS REQUIRED	DESCRIPTION	PART NUMBER
DP46HC	1	full cover	00C32-017A-03
DP60HC	1	full cover	00C32-022D-04
DP67HC	1	full cover	00C32-022D-01
DP72HC	1	full cover	00C32-022D-03
DP93HC	2	section cover (order two)	00C32-017A-01
DP119HC	2	kit contains left and right covers	00C32-022D-02

DESCRIPTION	UNIT(S)	PART NUMBER
-------------	---------	-------------

SALAD BAR - SNEEZE GUARDS		
Sneeze Guard	SPE36HC-S	00C23-160D-01
Sneeze Guard	SPE48HC-S	00C23-160D-02
Sneeze Guard	SPE60HC-S	00C23-160D-03
Sneeze Guard	SPE72HC-S	00C23-160D-04

SALAD BAR - SNEEZE GUARD EXTENSION WALL FOR SINGLE SIDE SERVICE		
Add-on wall for single side service	SPE36HC-S	00C23-162D-02
Add-on wall for single side service	SPE48HC-S	00C23-162D-03
Add-on wall for single side service	SPE60HC-S	00C23-162D-04
Add-on wall for single side service	SPE72HC-S	00C23-162D-05

SALAD BAR - FOLDING TRAY SLIDES		
Folding tray slide (order 2 for dual-side service)	SPE36HC-S	408-018D-36
Folding tray slide (order 2 for dual-side service)	SPE48HC-S	408-018D-48
Folding tray slide (order 2 for dual-side service)	SPE60HC-S	408-018D-60
Folding tray slide (order 2 for dual-side service)	SPE72HC-S	408-018D-72







WORKTOPS & UNDERCOUNTERS

FOUNDATION OF KITCHEN LAYOUTS BUILT TO PERFORM

WORKTOPS

Stainless steel top

Full electronic control

Interior thermometer

Self-closing doors

with 120° stay-open feature,
on cartridge style hinges

Easy door removal

for service and cleaning

Magnetic gasket

attached to each door
for positive seal

Two epoxy-coated steel wire shelves per section

Field-reversible doors

On select models

6" heavy duty casters

3" casters or 6" leg option available
at no charge when specified on order



DESIGNED TO PERFORM IN HIGH AMBIENT CONDITIONS

3 YEAR PARTS & LABOR WARRANTY WITH AN ADDITIONAL 4 YEAR COMPRESSOR WARRANTY

MADE IN USA



REMOVABLE BACKSPASH
available as an option, as well as a Flat
Top, or a Foamed-in-Place backsplash



FIELD REVERSIBLE DOORS
for layout flexibility

ACCESS OPTIONS

- Doors
- Drawers

AGENCY CERTIFICATIONS





EXTERIOR FINISHES

- Stainless steel with galvanized back
- Stainless steel with stainless back

INTERIOR FINISHES

- Corrosion-resistant aluminum
- Stainless

AVAILABLE ACCESSORIES

- Composite cutting boards (only available on rear-mounted worktops)
- Bun tray rack
- Locks (doors only)
- Glass doors (rear-mount units only)
- 16-gauge stainless steel top

AVAILABLE OPTIONS

- Left hand hinge doors
- Remote models available

BACKSPLASH OPTIONS

- Removable
- 4" foamed-in-place
- Flat-top

MOUNTING OPTIONS

- 6" casters
- 3" casters (allows for ADA compliant working height)
- 6" legs

WORKTOPS

Rear-Mounted Refrigeration

REFRIGERATORS - DOORS

MAINTAINS PRODUCT TEMPERATURES OF 36-38°F.

MODEL WIDTH	MODEL DEPTH	MODEL #	DOORS/SHELVES	VOLTS	HP	AMPS	CUBIC FEET	WIDTH	DEPTH	HEIGHT	CRATED WEIGHT	BACK SPLASH
24"	Solid	WTR24AHC	1/2	115	1/6	2	5.16	24	32	33.63	168	REMOVABLE
	Solid	WTR24AHC-FIP	1/2	115	1/6	2	5.16	24	32	33.63	182	FOAM
	Solid	WTR24AHC-FLT	1/2	115	1/6	2	5.16	24	32	29.63	168	FLAT TOP
27"	Solid	WTR27AHC	1/2	115	1/6	2	6.13	27	32	33.63	184	REMOVABLE
	Solid	WTR27AHC-FIP	1/2	115	1/6	2	6.13	27	32	33.63	172	FOAM
	Solid	WTR27AHC-FLT	1/2	115	1/6	2	6.13	27	32	29.63	180	FLAT TOP
32"	Solid	WTR32AHC	1/2	115	1/6	2	7.2	32	32	33.63	184	REMOVABLE
	Solid	WTR32AHC-FIP	1/2	115	1/6	2	7.2	32	32	33.63	172	FOAM
	Solid	WTR32AHC-FLT	1/2	115	1/6	2	7.2	32	32	29.63	180	FLAT TOP
36"	Solid	WTR36AHC	2/4	115	1/6	2	8.5	36	32	33.63	216	REMOVABLE
	Solid	WTR36AHC-FIP	2/4	115	1/6	2	8.5	36	32	33.63	226	FOAM
	Solid	WTR36AHC-FLT	2/4	115	1/6	2	8.5	36	32	29.63	212	FLAT TOP
48"	Solid	WTR48AHC	2/4	115	1/6	2.2	11.82	48	32	33.63	258	REMOVABLE
	Solid	WTR48AHC-FIP	2/4	115	1/6	2.2	11.82	48	32	33.63	266	FOAM
	Solid	WTR48AHC-FLT	2/4	115	1/6	2.2	11.82	48	32	29.63	235	FLAT TOP
60"	Solid	WTR60AHC	2/4	115	1/5	3	14.75	60	32	33.63	312	REMOVABLE
	Solid	WTR60AHC-FIP	2/4	115	1/5	3	14.75	60	32	33.63	322	FOAM
	Solid	WTR60AHC-FLT	2/4	115	1/5	3	14.75	60	32	29.63	300	FLAT TOP
72"	Solid	WTR72AHC	3/6	115	1/5	3	17.88	72	32	33.63	334	REMOVABLE
	Solid	WTR72AHC-FIP	3/6	115	1/5	3	17.88	72	32	33.63	362	FOAM
	Solid	WTR72AHC-FLT	3/6	115	1/5	3	17.88	72	32	29.63	347	FLAT TOP

NEW

Depth measurement includes handles. For total height, add 3 or 6 inches, based on your mounting choice.

BACKSPLASH OPTIONS	
SUFFIX	EXTERIOR
(standard)	Removable backsplash
FIP	4" foamed-in-place backsplash
FLT	Flat-top with no backsplash

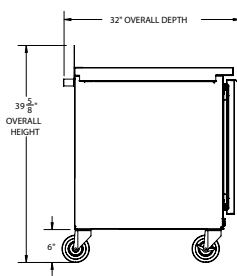

STANDARD

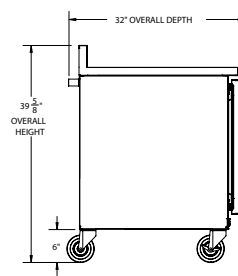

FOAMED IN PLACE

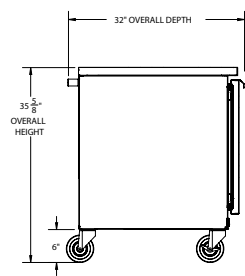

FLAT-TOP

REFRIGERATORS (SHALLOW DEPTH) - DOORS

MAINTAINS PRODUCT TEMPERATURES OF 36-38°F.

MODEL WIDTH	DOOR TYPE	MODEL #	DOORS/ SHELVES	VOLTS	HP	AMPS	CUBIC FEET	WIDTH	DEPTH	HEIGHT	CRATED WEIGHT	BACK SPLASH
20"	Solid	WTR20HC	1/2	115	1/6	2	2.34	20	24.5	30.13	116	REMOVABLE
	Solid	WTR20HC-FIP	1/2	115	1/6	2	2.34	20	24.5	30.13	124	FOAM
	Solid	WTR20HC-FLT	1/2	115	1/6	2	2.34	20	24.5	26.13	119	FLAT TOP
27"	Solid	WTR27HC	1/2	115	1/6	2	5.25	27	29.88	33.63	161	REMOVABLE
	Solid	WTR27HC-FIP	1/2	115	1/6	2	5.25	27	29.88	33.63	161	FOAM
	Solid	WTR27HC-FLT	1/2	115	1/6	2	5.25	27	29.88	29.63	160	FLAT TOP
34"	Solid	WTR34HC	2/4	115	1/6	2	3.88	34	24.63	30.13	171	REMOVABLE
	Solid	WTR34HC-FIP	2/4	115	1/6	2	3.88	34	24.63	30.13	172	FOAM
	Solid	WTR34HC-FLT	2/4	115	1/6	2	3.88	34	24.63	26.13	172	FLAT TOP

Depth measurement includes handles. For total height, add 3 or 6 inches, based on your mounting choice.

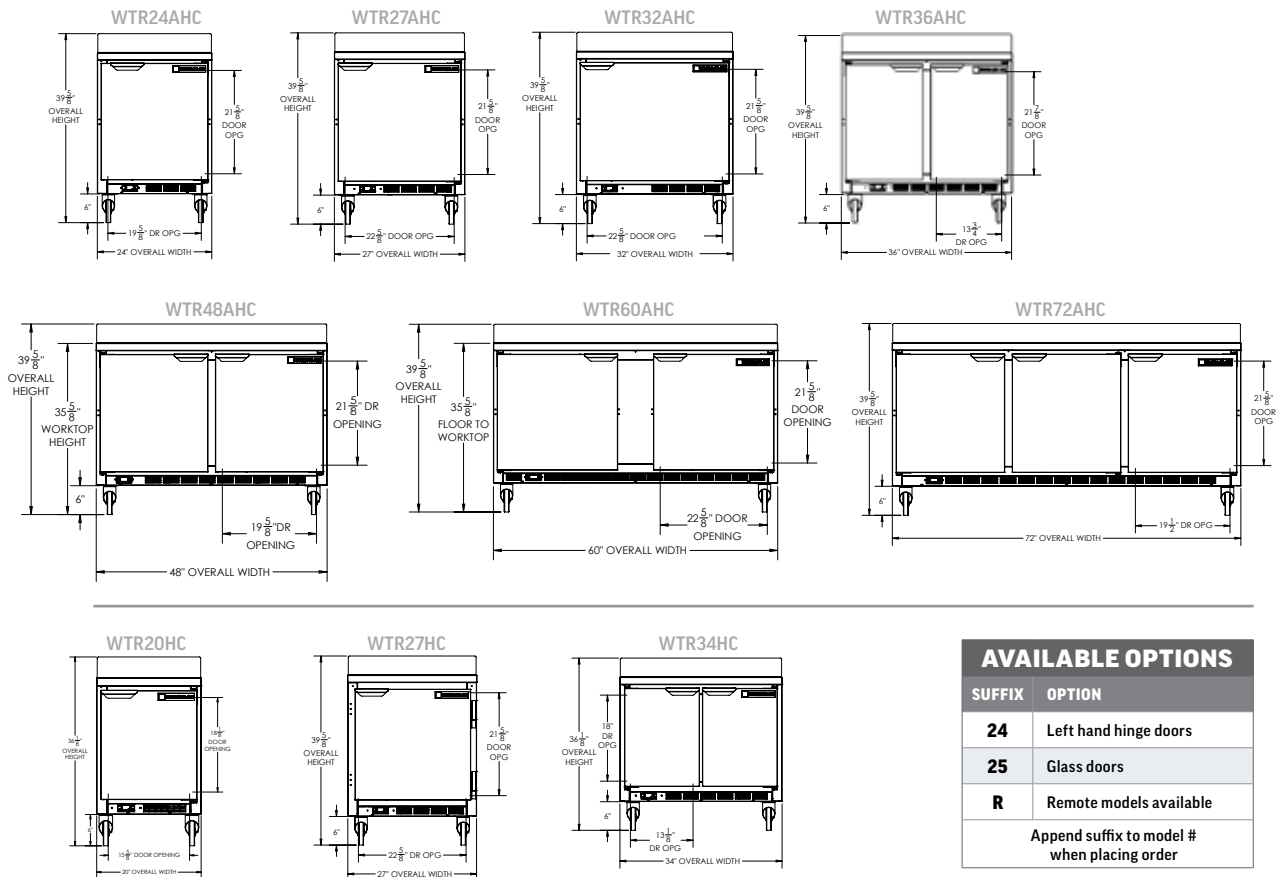

AVAILABLE OPTIONS

SUFFIX	OPTION
24	Left hand hinge doors
25	Glass doors
R	Remote models available
Append suffix to model # when placing order	

WORKTOPS

Rear-Mounted Refrigeration

REFRIGERATORS - DRAWERS

MAINTAINS PRODUCT TEMPERATURES OF 36-38°F.

NEW

MODEL WIDTH	MODEL #	DRAWERS	DOORS/SHELVES	VOLTS	HP	AMPS	CUBIC FEET	WIDTH	DEPTH	HEIGHT	CRATED WEIGHT	BACK SPLASH
27"	WTRD27AHC-2	2	-	115	1/6	2	6.13	27	32	33.63	202	REMOVABLE
	WTRD27AHC-2-FIP	2	-	115	1/6	2	6.13	27	32	33.63	202	FOAM
	WTRD27AHC-2-FLT	2	-	115	1/6	2	6.13	27	32	29.63	192	FLAT TOP
32"	WTRD32AHC-2	2	-	115	1/6	2	7.2	32	32	33.63	230	REMOVABLE
	WTRD32AHC-2-FIP	2	-	115	1/6	2	7.2	32	32	33.63	244	FOAM
	WTRD32AHC-2-FLT	2	-	115	1/6	2	7.2	32	32	29.63	226	FLAT TOP
36"	WTRD36AHC-2	2	-	115	1/6	2	8.5	36	32	33.63	244	REMOVABLE
	WTRD36AHC-2-FIP	2	-	115	1/6	2	8.5	36	32	33.63	258	FOAM
	WTRD36AHC-2-FLT	2	-	115	1/6	2	8.5	36	32	29.63	240	FLAT TOP
48"	WTRD48AHC-2	2	1/2	115	1/6	2.2	11.82	48	32	33.63	282	REMOVABLE
	WTRD48AHC-4	4	-	115	1/6	2.2	11.82	48	32	33.63	326	REMOVABLE
	WTRD48AHC-2-FIP	2	1/2	115	1/6	2.2	11.82	48	32	33.63	282	FOAM
	WTRD48AHC-4-FIP	4	-	115	1/6	2.2	11.82	48	32	33.63	334	FOAM
	WTRD48AHC-2-FLT	2	1/2	115	1/6	2.2	11.82	48	32	29.63	242	FLAT TOP
	WTRD48AHC-4-FLT	4	-	115	1/6	2.2	11.82	48	32	29.63	326	FLAT TOP

Depth measurement includes handles.
For total height, add 3 or 6 inches, based on your mounting choice.

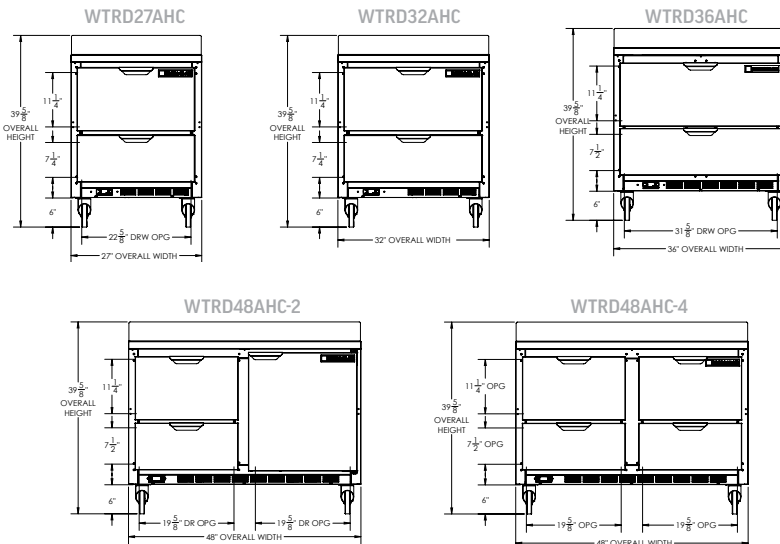

REFRIGERATORS - DRAWERS

MAINTAINS PRODUCT TEMPERATURES OF 36-38°F.

MODEL WIDTH	MODEL #	DRAWERS	DOORS/SHELVES	VOLTS	HP	AMPS	CUBIC FEET	WIDTH	DEPTH	HEIGHT	CRATED WEIGHT	BACK SPLASH
60"	WTRD60AHC-2	2	1/2	115	1/5	3	14.75	60	32	33.63	342	REMOVABLE
	WTRD60AHC-4	4	–	115	1/5	3	14.75	60	32	33.63	356	REMOVABLE
	WTRD60AHC-2-FIP	2	1/2	115	1/5	3	14.75	60	32	33.63	342	FOAM
	WTRD60AHC-4-FIP	4	–	115	1/5	3	14.75	60	32	33.63	386	FOAM
	WTRD60AHC-2-FLT	2	1/2	115	1/5	3	14.75	60	32	29.63	330	FLAT TOP
	WTRD60AHC-4-FLT	4	–	115	1/5	3	14.75	60	32	29.63	271	FLAT TOP
72"	WTRD72AHC-2	2	2/4	115	1/5	3	17.88	72	32	33.63	370	REMOVABLE
	WTRD72AHC-4	4	1/2	115	1/5	3	17.88	72	32	33.63	370	REMOVABLE
	WTRD72AHC-6	6	–	115	1/5	3	17.88	72	32	33.63	330	REMOVABLE
	WTRD72AHC-2-FIP	2	2/4	115	1/5	3	17.88	72	32	33.63	370	FOAM
	WTRD72AHC-4-FIP	4	1/2	115	1/5	3	17.88	72	32	33.63	370	FOAM
	WTRD72AHC-6-FIP	6	–	115	1/5	3	17.88	72	32	33.63	370	FOAM
	WTRD72AHC-2-FLT	2	2/4	115	1/5	3	17.88	72	32	29.63	370	FLAT TOP
	WTRD72AHC-4-FLT	4	1/2	115	1/5	3	17.88	72	32	29.63	330	FLAT TOP
	WTRD72AHC-6-FLT	6	–	115	1/5	3	17.88	72	32	29.63	422	FLAT TOP

*Depth measurement includes handles.
For total height, add 3 or 6 inches, based on your mounting choice.*

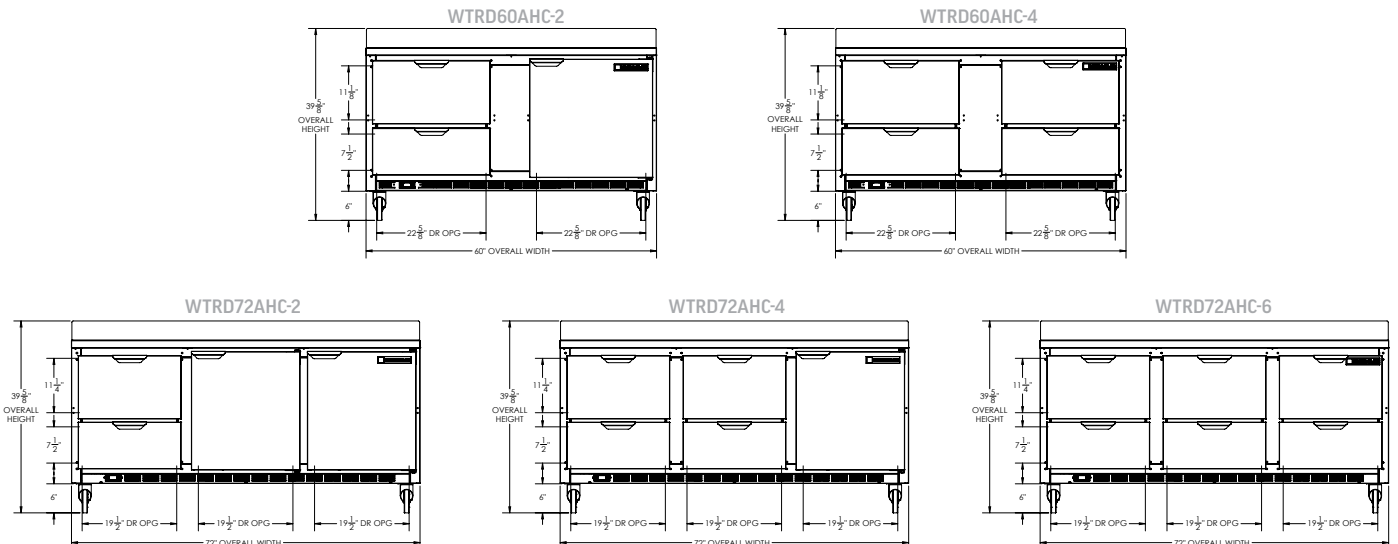

WORKTOPS

Rear-Mounted Refrigeration

FREEZERS - DOORS

MAINTAINS PRODUCT TEMPERATURE AT 0° F AND BELOW.

MODEL WIDTH	MODEL DEPTH	MODEL #	DOORS/ SHELVES	VOLTS	HP	AMPS	CUBIC FEET	WIDTH	DEPTH	HEIGHT	CRATED WEIGHT	BACK SPLASH
24"	Solid	WTF24AHC	1/2	115	1/4	2.5	4.9	24	32	33.63	190	REMOVABLE
	Solid	WTF24AHC-FIP	1/2	115	1/4	2.5	4.9	24	32	33.63	184	FOAM
	Solid	WTF24AHC-FLT	1/2	115	1/4	2.5	4.9	24	32	29.63	184	FLAT TOP
27"	Solid	WTF27AHC	1/2	115	1/4	2.5	6.13	27	32	33.63	190	REMOVABLE
	Solid	WTF27AHC-FIP	1/2	115	1/4	2.5	6.13	27	32	33.63	202	FOAM
	Solid	WTF27AHC-FLT	1/2	115	1/4	2.5	6.13	27	32	29.63	184	FLAT TOP
32"	Solid	WTF32AHC	1/2	115	1/3+	4	7.2	32	32	33.63	220	REMOVABLE
	Solid	WTF32AHC-FIP	1/2	115	1/3+	4	7.2	32	32	33.63	230	FOAM
	Solid	WTF32AHC-FLT	1/2	115	1/3+	4	7.2	32	32	29.63	215	FLAT TOP
36"	Solid	WTF36AHC	2/4	115	1/4	6	8.69	36	32	33.63	232	REMOVABLE
	Solid	WTF36AHC-FIP	2/4	115	1/4	6	8.69	36	32	33.63	246	FOAM
	Solid	WTF36AHC-FLT	2/4	115	1/2	6	8.69	36	32	29.63	218	FLAT TOP
48"	Solid	WTF48AHC	2/4	115	1/2	7	11.04	48	32	33.63	294	REMOVABLE
	Solid	WTF48AHC-FIP	2/4	115	1/2	7	11.04	48	32	33.63	214	FOAM
	Solid	WTF48AHC-FLT	2/4	115	1/2	7	11.04	48	32	29.63	246	FLAT TOP
60"	Solid	WTF60AHC	2/4	115	1/2	7	14.39	60	32	33.63	320	REMOVABLE
	Solid	WTF60AHC-FIP	2/4	115	1/2	7	14.39	60	32	33.63	340	FOAM
	Solid	WTF60AHC-FLT	2/4	115	1/2	7	14.39	60	32	29.63	320	FLAT TOP

NEW

*Depth measurement includes handles.
For total height, add 3 or 6 inches, based on your mounting choice.*

BACKSPLASH OPTIONS	
SUFFIX	EXTERIOR
(standard)	Removable backsplash
FIP	4" foamed-in-place backsplash
FLT	Flat-top with no backsplash

AVAILABLE OPTIONS	
SUFFIX	OPTION
24	Left hand hinge doors
25	Glass doors
R	Remote models available
Append suffix to model # when placing order	

FREEZERS (SHALLOW DEPTH) - DOORS

MAINTAINS PRODUCT TEMPERATURE AT 0° F AND BELOW.

MODEL WIDTH	DOOR TYPE	MODEL #	DOORS/SHELVES	VOLTS	HP	AMPS	CUBIC FEET	WIDTH	DEPTH	HEIGHT	CRATED WEIGHT	BACK SPLASH
20"	Solid	WTF20HC	1/2	115	1/4	2.5	2.34	20	24.50	30.13	134	REMOVABLE
	Solid	WTF20HC-FIP	1/2	115	1/4	2.5	2.34	20	24.50	30.13	134	FOAM
	Solid	WTF20HC-FLT	1/2	115	1/4	2.5	2.34	20	24.50	26.13	134	FLAT TOP
27"	Solid	WTF27HC	1/2	115	1/4	2.5	5.25	27	29.88	33.63	185	REMOVABLE
	Solid	WTF27HC-FIP	1/2	115	1/4	2.5	5.25	27	29.88	33.63	192	FOAM
	Solid	WTF27HC-FLT	1/2	115	1/4	2.5	5.25	27	29.88	29.63	185	FLAT TOP

*Depth measurement includes handles.
For total height, add 3 or 6 inches, based on your mounting choice.*

DUAL-TEMPS - DOORS

MAINTAINS PRODUCT TEMPERATURES OF 36-38°F (REFRIGERATOR), AND 0°F (FREEZER).

MODEL WIDTH	DOOR TYPE	MODEL #	DOORS/SHELVES	VOLTS	HP	AMPS	CUBIC FEET	WIDTH	DEPTH	HEIGHT	CRATED WEIGHT	BACK SPLASH
48"	Solid	WTRF48AHC	2/4	115	R: 1/6 F: 1/4	R: 2.0 F: 2.5	L: 5.31 R: 5.31	48	32	33.63	302	REMOVABLE
		WFR48AHC										

*"RF" in the model # designates refrigerator on the left, freezer on the right.
"FR" in the model # designates freezer on the left, refrigerator on the right.*

*Depth measurement includes handles.
For total height, add 3 or 6 inches, based on your mounting choice.*



WORKTOPS

Rear-Mounted Refrigeration

FREEZERS - DRAWERS

MAINTAINS PRODUCT TEMPERATURE AT 0° F AND BELOW.

MODEL WIDTH	MODEL #	DRAWERS	DOORS/SHELVES	VOLTS	HP	AMPS	CUBIC FEET	WIDTH	DEPTH	HEIGHT	CRATED WEIGHT	BACK SPLASH
27"	WTFD27AHC-2	2	—	115	1/4	2.5	6.13	27	32	33.63	218	REMOVABLE
	WTFD27AHC-2-FIP	2	—	115	1/4	2.5	6.13	27	32	33.63	218	FOAM
	WTFD27AHC-2-FLT	2	—	115	1/4	2.5	6.13	27	32	29.63	228	FLAT TOP
32"	WTFD32AHC-2	2	—	115	1/3+	4	7.2	32	32	33.63	248	REMOVABLE
	WTFD32AHC-2-FIP	2	—	115	1/3+	4	7.2	32	32	33.63	248	FOAM
	WTFD32AHC-2-FLT	2	—	115	1/3+	4	7.2	32	32	29.63	258	FLAT TOP
36"	WTFD36AHC-2	2	—	115	1/2	6	8.69	36	32	33.63	264	REMOVABLE
	WTFD36AHC-2-FIP	2	—	115	1/2	6	8.69	36	32	33.63	262	FOAM
	WTFD36AHC-2-FLT	2	—	115	1/2	6	8.69	36	32	29.63	264	FLAT TOP

NEW

*Depth measurement includes handles.
For total height, add 3 or 6 inches, based on your mounting choice.*

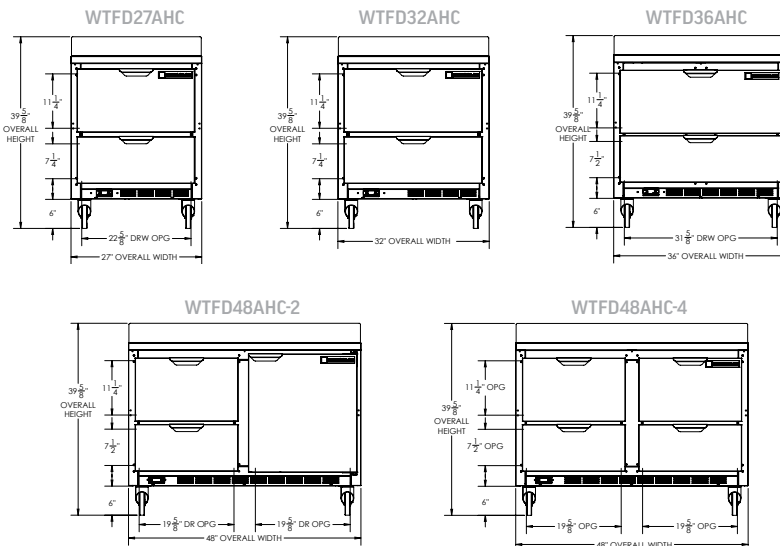

FREEZERS - DRAWERS

MAINTAINS PRODUCT TEMPERATURE AT 0° F AND BELOW.

MODEL WIDTH	MODEL #	DRAWERS	DOORS/SHELVES	VOLTS	HP	AMPS	CUBIC FEET	WIDTH	DEPTH	HEIGHT	CRATED WEIGHT	BACK SPLASH
48"	WTFD48AHC-2	2	1/2	115	1/2	7	11.44	48	32	33.63	325	REMOVABLE
	WTFD48AHC-4	4	–	115	1/2	7	11.44	48	32	33.63	356	REMOVABLE
	WTFD48AHC-2-FIP	2	1/2	115	1/2	7	11.44	48	32	33.63	324	FOAM
	WTFD48AHC-4-FIP	4	–	115	1/2	7	11.44	48	32	33.63	356	FOAM
	WTFD48AHC-2-FLT	2	1/2	115	1/2	7	11.44	48	32	29.63	310	FLAT TOP
	WTFD48AHC-4-FLT	4	–	115	1/2	7	11.44	48	32	29.63	356	FLAT TOP
60"	WTFD60AHC-2	2	1/2	115	1/2	7	14.36	60	32	33.63	390	REMOVABLE
	WTFD60AHC-4	4	–	115	1/2	7	14.36	60	32	33.63	392	REMOVABLE
	WTFD60AHC-2-FIP	2	1/2	115	1/2	7	14.36	60	32	33.63	390	FOAM
	WTFD60AHC-4-FIP	4	–	115	1/2	7	14.36	60	32	33.63	392	FOAM
	WTFD60AHC-2-FLT	2	1/2	115	1/2	7	14.36	60	32	29.63	390	FLAT TOP
	WTFD60AHC-4-FLT	4	–	115	1/2	7	14.36	60	32	29.63	392	FLAT TOP

Depth measurement includes handles.
For total height, add 3 or 6 inches, based on your mounting choice.

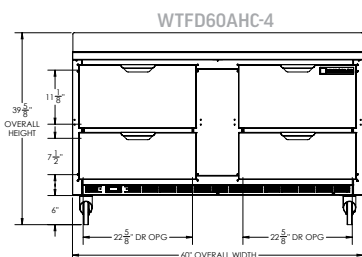
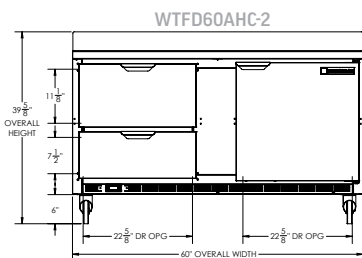

DRAWER PAN CONFIGURATIONS for WTRD and WTFD units

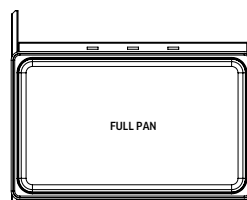

WTRD27 / WTRD32 / WTRD60
WTFD27 / WTFD32 / WTFD60

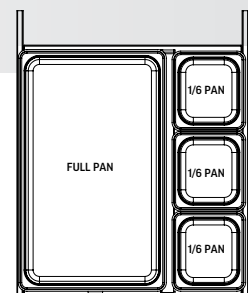

WTRD46 / WTRD67 / WTRD93 / WTRD119
WTFD46 / WTFD67 / WTFD93 / WTFD119

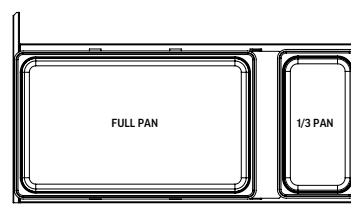

WTRD36 / WTFD36

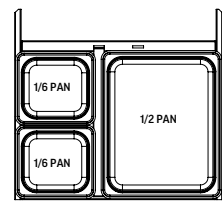

WTRD48 / WTRD72 / WTFD48

WORKTOPS

Side-Mounted Refrigeration

REFRIGERATORS - DOORS

MAINTAINS PRODUCT TEMPERATURES OF 36-38°F.

MODEL WIDTH	DOOR TYPE	MODEL #	DOORS/SHELVES	VOLTS	HP	AMPS	CUBIC FEET	WIDTH	DEPTH	HEIGHT	CRATED WEIGHT	BACK SPLASH
41"	Solid	WTR41AHC	1/2	115	1/6	2.2	7.94	41	34	33.5	290	FOAM
46"	Solid	WTR46AHC	1/2	115	1/6	3	10.8	46	34	33.5	325	FOAM
67"	Solid	WTR67AHC	2/4	115	1/5	3	18.97	67	34	33.5	400	FOAM
93"	Solid	WTR93AHC	3/6	115	1/3	5	29.7	93	34	33.5	528	FOAM
119"	Solid	WTR119AHC	4/8	115	1/3	5	40.12	119	34	33.5	675	FOAM

Depth measurement includes handles.

For total height, add 3 or 6 inches, based on your mounting choice.

AVAILABLE OPTIONS	
SUFFIX	OPTION
24	Left hand hinge doors
R	Remote models available
Append suffix to model # when placing order	

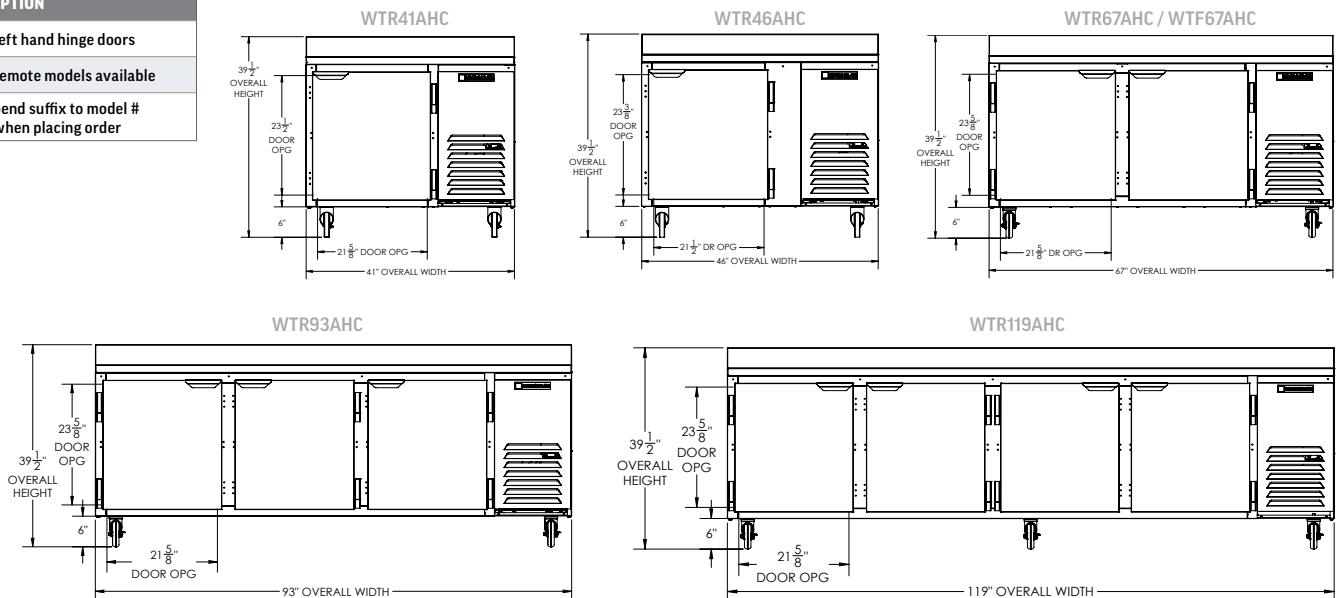

FREEZERS - DOORS

MAINTAINS PRODUCT TEMPERATURE AT 0° F AND BELOW.

MODEL WIDTH	DOOR TYPE	MODEL #	DOORS/SHELVES	VOLTS	HP	AMPS	CUBIC FEET	WIDTH	DEPTH	HEIGHT	CRATED WEIGHT	BACK SPLASH
67"	Solid	WTF67AHC	2/4	115	3/4	8.9	20.8	67	34	33.50	431	FOAM

Depth measurement includes handles.

For total height, add 3 or 6 inches, based on your mounting choice.

REFRIGERATORS - DRAWERS

MAINTAINS PRODUCT TEMPERATURES OF 36-38°F.

MODEL WIDTH	MODEL #	DRAWERS	DOORS/SHELVES	VOLTS	HP	AMPS	CUBIC FEET	WIDTH	DEPTH	HEIGHT	CRATED WEIGHT	BACK SPLASH
46"	WTRD46AHC-2	2	–	115	1/5	3	10.8	46	34	33.5	282	FOAM
	WTRD67AHC-2	2	1/2	115	1/5	3	18.97	67	34	33.5	435	FOAM
67"	WTRD67AHC-4	4	–	115	1/5	3	18.97	67	34	33.5	450	FOAM
	WTRD93AHC-2	2	2/4	115	1/3	5	29.7	93	34	33.5	562	FOAM
93"	WTRD93AHC-4	4	1/2	115	1/3	5	29.7	93	34	33.5	588	FOAM
	WTRD93AHC-6	6	–	115	1/3	5	29.7	93	34	33.5	606	FOAM
119"	WTRD119AHC-2	2	3/6	115	1/3	4.9	40.12	119	34	33.5	604	FOAM
	WTRD119AHC-4	4	2/4	115	1/3	4.9	40.12	119	34	33.5	604	FOAM
	WTRD119AHC-6	6	1/2	115	1/3	4.9	40.12	119	34	33.5	604	FOAM
	WTRD119AHC-8	8	–	115	1/3	4.9	40.12	119	34	33.5	604	FOAM

*Depth measurement includes handles.
For total height, add 3 or 6 inches, based on your mounting choice.*

