

COLDIN-3™ MSF-AN SERIES

Flat Lid Display Freezers

MODELS

- MSF-31AN
- MSF-43AN
- MSF-52AN
- MSF-71AN



MSF-43AN



FEATURES

CONSTRUCTION

- Standard interior LED lighting with separate on/off switch
- Tempered glass sliding lids
- White zinc-coated baked-on enamel steel exterior
- Painted white powder-coated steel interior
- Flat top three-compartment baskets
- Removable rubber bumper guards on grille side
- Heavy-duty casters, two locking
- Bottom drain with plug
- Lid lock and keys
- The unobtrusive frame around the glass lids ensures a highly visible display
- External analog thermometer display
- Control panel with adjustable temperature range of +10 to -18°F
- Low energy consumption

REFRIGERATION

- Refrigerant: R290
- Temperature range: -18° to 10°F (-27° to -12°C)

WARRANTY

- Standard one year parts and labor

OPTIONS

- Replacement baskets

STANDARD BASKETS

MSF-AN model merchandisers are supplied with equally-sized baskets and two fixed dividers per basket.

MODEL	NO. OF BASKETS
MSF-31AN	2
MSF-43AN	3
MSF-52AN	4
MSF-71AN	5

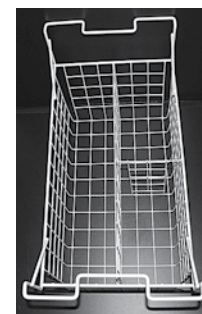
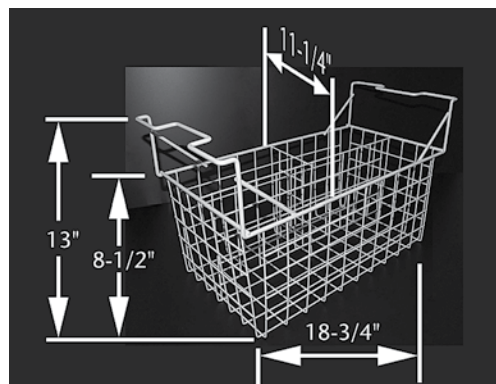

One vertical and one horizontal fixed divider in each basket.

TECHNICAL SPECIFICATIONS

Models	MSF-31AN	MSF-43AN	MSF-52AN	MSF-71AN
Crated Weight (lbs) (kg)	130 (59)	154 (70)	179 (81)	218 (99)
Crated Height (in) (mm)	39-1/2 (1003)	39-1/2 (1003)	39-1/2 (1003)	39-1/2 (1003)
Crated Width (in) (mm)	34 (864)	46 (1168)	55 (1397)	74 (1880)
Crated Depth (in) (mm)	30 (762)	30 (762)	30 (762)	30 (762)
Interior Height (in) (mm)	25 (635)	25 (635)	25 (635)	25 (635)
Interior Width (in) (mm)	25-1/2 (648)	37-1/2 (953)	43-1/2 (1105)	65-1/2 (1664)
Interior Depth (in) (mm)	21-1/2 (546)	21-1/2 (546)	21-1/2 (546)	21-1/2 (546)
Overall Height (in) (mm)	33 (838)	33 (838)	33 (838)	33 (838)
Overall Width (in) (mm)	31 (787)	43 (1092)	52 (1321)	71 (1803)
Overall Depth (in) (mm)	27 (686)	27 (686)	27 (686)	27 (686)
Gross Cubage (CuFt) (L)	7.4 (209.5)	11.1 (314.3)	13.8 (390.7)	20.0 (566)
Number of Baskets*	2	3	4	5
Number of Casters	4	4	4	4
Condensing Unit Size	1/3 HP	1/3 HP	1/3 HP	2/3 HP
Refrigerant	R290	R290	R290	R290
Electrical Characteristics	115/60/1	115/60/1	115/60/1	115/60/1
NEMA Plug Configuration	5-15P	5-15P	5-15P	5-15P
Total Amp Draw	1.3	1.4	2.0	4.1

* Includes 1 horizontal and 1 vertical fixed divider per basket.

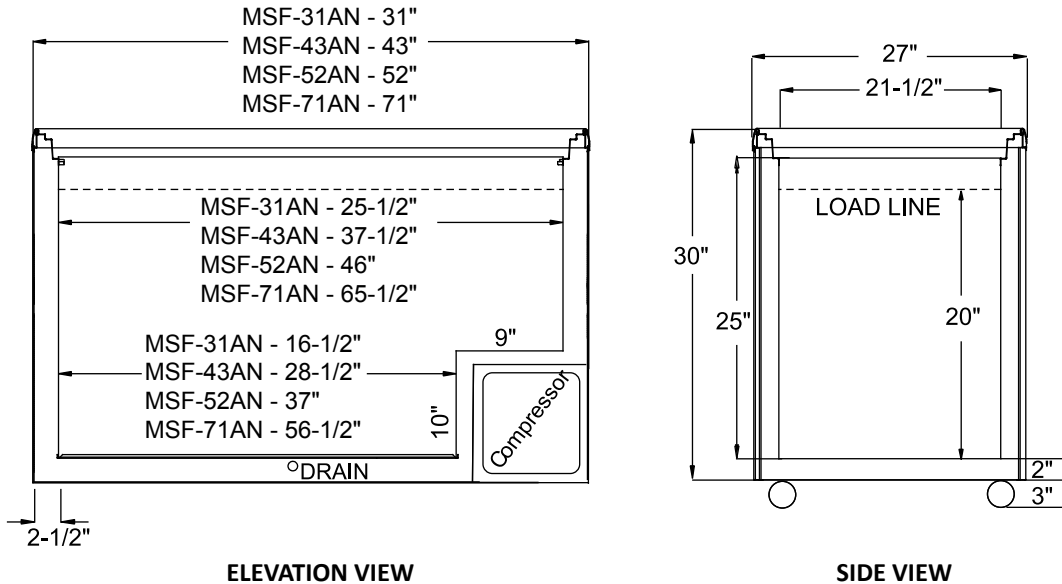

LISTINGS



HOOKUP

Via plug in, 6-1/2 ft. long, flexible 3 wire
14AWG/3 cord with molded plug.



NEMA 5-15P

BID SPECIFICATIONS

Item no. MSF-_____AN

Provide _____ ()

Flat Lid Display Freezer(s)

Master-Bilt® model MSF-_____AN.

Freezer to be constructed of a white zinc-coated baked-on enamel on steel exterior with painted white powder-coated steel interior. Freezer to be

furnished with standard LED interior lighting. Also standard with baskets, integrated basket dividers, external thermometer and lock. Additionally, it will be provided with heavy-duty casters and a defrost water drain. Lids will contain tempered safety glass.

Refrigeration system will use

R290 refrigerant in all models. The temperature range will be -18° to 10°F (-27° to -12°C).

Freezer to have standard one year parts and labor warranty.

Freezer to be ETL listed in the U.S. and Canada and ETL Sanitation listed.

**NOTE: Cabinet designed for optimum performance in air-conditioned area at 75°F ambient and 55% relative humidity.
All specifications within this publication subject to change without notice.**

COLDIN-3™ MSC-A SERIES

Curved Lid Display Freezers

MODELS

- MSC-31AA
- MSC-41AA
- MSC-49AA
- MSC-66AN



MSC-66AN

MSC-49AA



FEATURES

CONSTRUCTION

- Standard interior LED lighting with separate on/off switch
- Curved tempered glass sliding lids
- White zinc-coated baked-on enamel steel exterior
- Painted white powder-coated steel interior
- Removable rubber bumper guards on grille side
- Heavy-duty casters, two locking
- Bottom drain with plug
- Lid lock and keys
- The unobtrusive frame around the glass lids ensures a highly visible display
- External analog thermometer display
- Control panel with adjustable temperature range of +10 to -18°F
- Low energy consumption

REFRIGERATION

- Refrigerant: R290
- Temperature range: -18° to 10°F (-27° to -12°C)

WARRANTY

- Standard one year parts and labor

OPTIONS

- Extra basket dividers
- Replacement baskets

STANDARD BASKETS

MSC-A models are supplied with equally-sized angled baskets and one adjustable horizontal divider per basket.

MODEL	NO. OF BASKETS/DIVIDERS
MSC-31AA	3/3
MSC-41AA	4/4
MSC-49AA	5/5
MSC-66AN	6/6

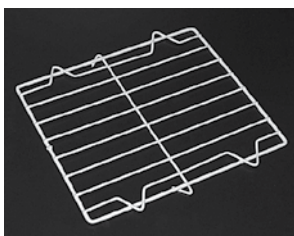

Horizontal divider

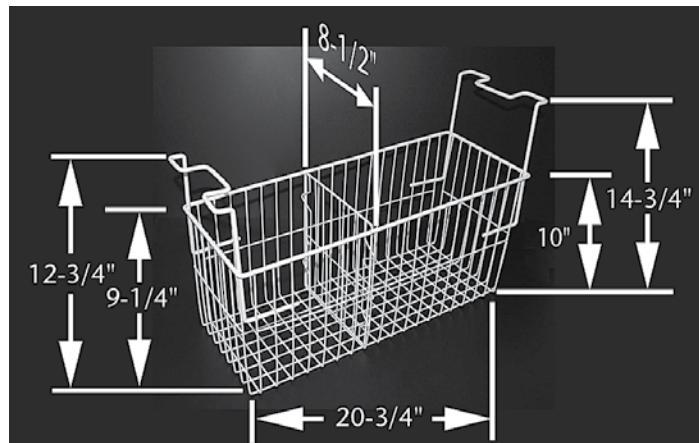

TECHNICAL SPECIFICATIONS

Models	MSC-31AA	MSC-41AA	MSC-49AA	MSC-66AN
Crated Weight (lbs) (kg)	146 (66)	150 (68)	181 (82)	231 (105)
Crated Height (in) (mm)	35-1/4 (895)	35-1/4 (895)	35-1/4 (895)	40 (1016)
Crated Width (in) (mm)	34-5/8 (880)	42-1/2 (1080)	52 (1320)	69-1/2 (1765)
Crated Depth (in) (mm)	30-3/8 (770)	30-3/8 (770)	30-3/8 (770)	30-1/2 (775)
Interior Height (in) (mm)	21 (533)	21 (533)	21 (533)	21 (533)
Interior Width (in) (mm)	25-7/8 (657)	35-3/8 (899)	43-1/4 (1099)	60-7/8 (1546)
Interior Depth (in) (mm)	21-1/2 (546)	21-1/2 (546)	21-1/2 (546)	21-1/2 (546)
Overall Height (in) (mm)	33-1/2 (850)	33-1/2 (850)	33-1/2 (850)	33-1/2 (851)
Overall Width (in) (mm)	31-1/2 (800)	39-3/8 (1000)	48-7/8 (1240)	66-1/2 (1689)
Overall Depth (in) (mm)	27-3/8 (694)	27-3/8 (694)	27-3/8 (694)	27-3/8 (695)
Gross Cubage (CuFt) (L)	7.2 (203)	9.7 (274)	12.7 (359)	20.3 (574.8)
Number of Baskets*	3	4	5	6
Number of Casters	4	4	4	4
Condensing Unit Size	1/3 HP	3/8 HP	3/8 HP	3/4 HP
Refrigerant	R290	R290	R290	R290
Electrical Characteristics	115/60/1	115/60/1	115/60/1	115/60/1
NEMA Plug Configuration	5-15P	5-15P	5-15P	5-15P
Total Amp Draw	1.3	1.4	2.0	4.1

* Includes 1 divider per basket.

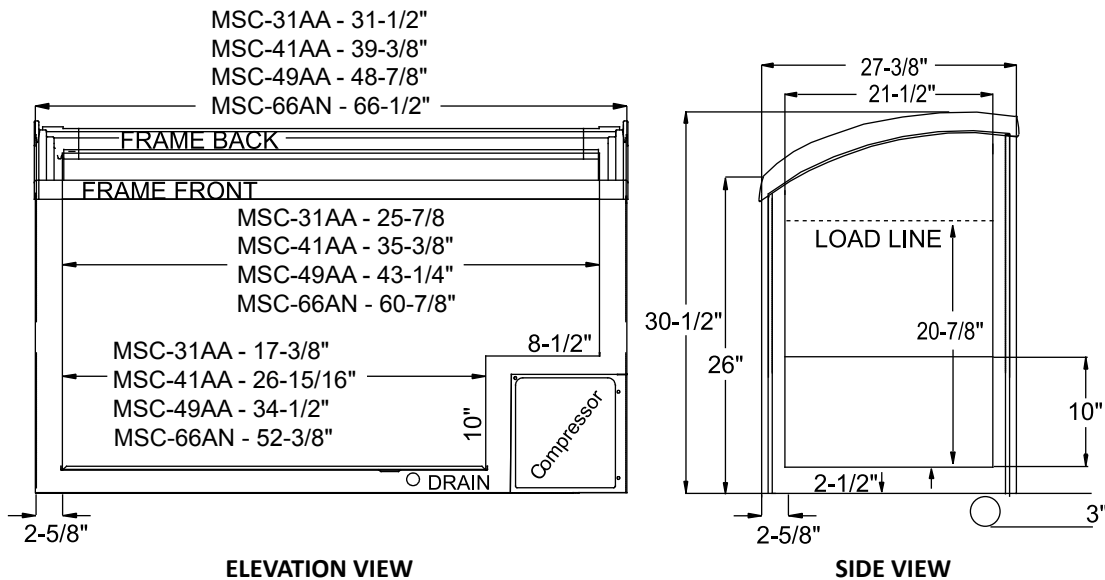

LISTINGS



HOOKUP

Via plug in, 6-1/2 foot long, flexible 3 wire
14AWG/3 cord with molded plug.



NEMA 5-15P

BID SPECIFICATIONS

Item no. MSC-____A

Provide _____ ()

Curved Lid Display Freezer(s)

Master-Bilt model MSC-____A.

Freezer to be constructed of a white zinc-coated baked-on enamel on steel exterior with painted white powder-coated steel interior. Freezer to be

furnished with standard LED interior lighting. Also standard with baskets, basket dividers, thermometer and lock. Additionally, it will be provided with heavy-duty casters and a defrost water drain. Lids will contain tempered safety glass.

Refrigeration system will use R290

refrigerant in all models.

The temperature range will be -18° to 10°F (-27° to -12°C).

Freezer to have standard one year parts and labor warranty.

Freezer to be ETL listed in the U.S. and Canada and ETL Sanitation listed.

**NOTE: Cabinet designed for optimum performance in air-conditioned area at 75°F ambient and 55% relative humidity.
All specifications within this publication subject to change without notice.**