



HAWCO
PRODUCTS LTD.



QUANTERNARY SANITIZER

TEST PROCEDURE

REQUIRED CONDITIONS:

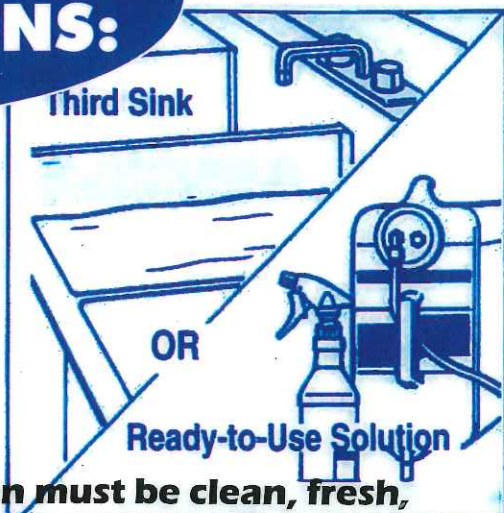

Sanitizer solution must be clean, fresh, and 200ppm concentration.

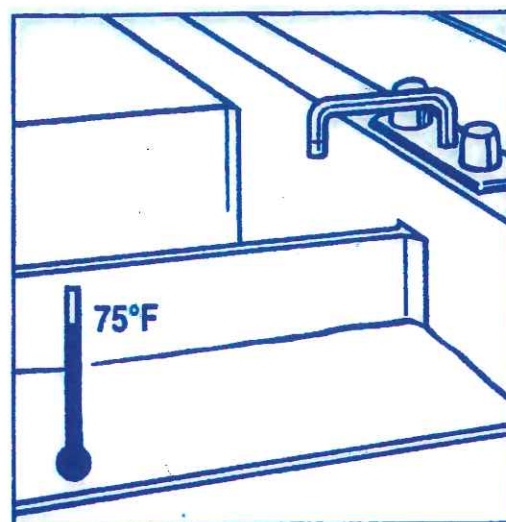

Solution must be room temperature.

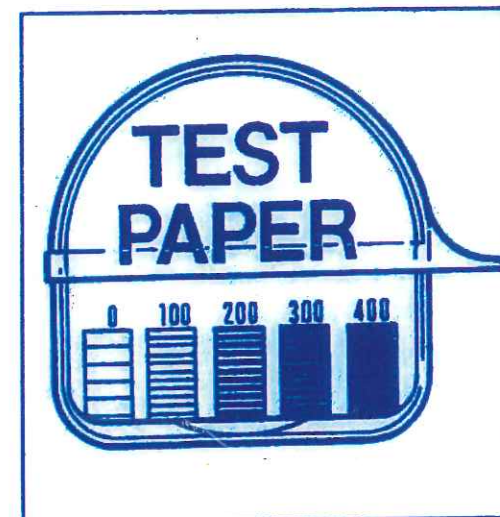

Test paper must be clean and dry.

TESTING:

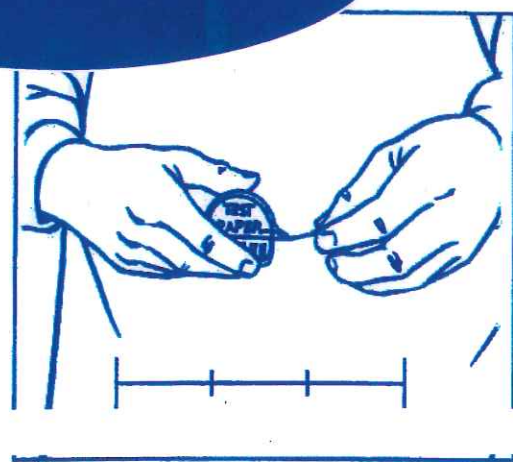

Remove 1.5" of test paper

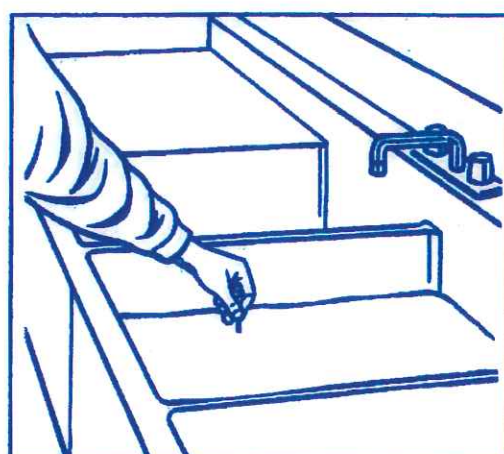

Dip test paper and hold still for 10 seconds. DO NOT SHAKE PAPER.

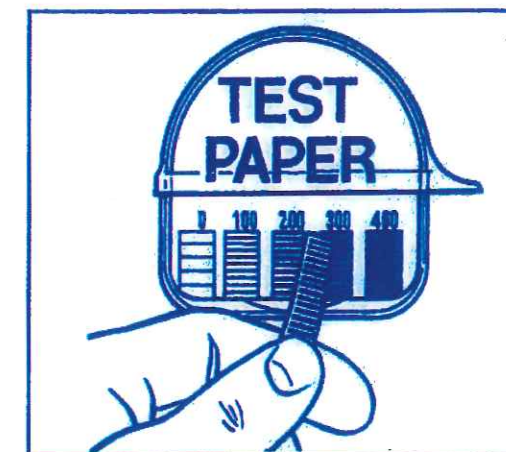

Compare to chart on test paper dispenser immediately. Solution should be 200ppm concentration.

www.diamondproducts.ca • www.hawcoproducts.com

61 SHAVER ST. P.O. BOX 1507
BRANTFORD, ONTARIO N3T 5V6

TEL: 519.759.2443 • FAX: 519.758.0371
DIAMOND SERVICE: 1.866.878.7951